

Owner's Manual

V 1.3

U2512 Series Inverters

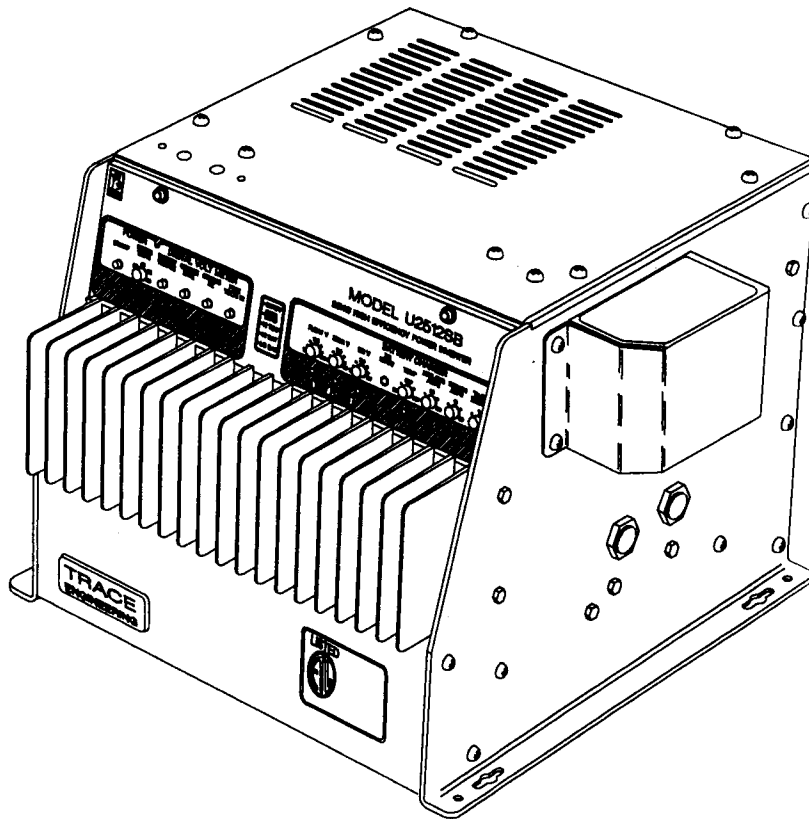

Trace Engineering Company, Inc.
5916 195thNE
Arlington, Washington, USA 98223
Phone (360) 435-8826
Fax (360) 435-2229
<http://www.traceengineering.com>

P/N 875-1

Torque Specifications for All Trace Engineering Inverters

The following insert provides torque specifications for all Trace Engineering inverter's AC and DC connections. It is intended as a guideline for those units which do not have suggested torques in the precautions or installation sections of the owner's manual.

Proper torque of each terminal combined with proper wire size (as suggested in the manual and governed by the NEC), is the only way to ensure proper operation of any Trace product.

Warning!! Read all sections of the owner's manual for all products being used in the installation. Follow manufacturer recommendations. This sheet is applicable to Trace Engineering products only. Be sure to read all precautions and safety information before beginning installation.

Recommended Torque for AC Connections

- Torque all AC connections to 20 **inch-pounds**.

Recommended DC Terminal Torque

- Torque all DC terminal connection to 10-12 **foot-pounds**.



Table Of Contents

UL Safety Instructions

General Precautions	1
Personal Precautions	4

Operation

Front Panel	5
Start-up	5
Search Mode Control	5
Battery Over Discharge Protection	7
Protection Circuitry	8
Indicator Lamps	8

Theory of Operation

Waveform	9
Regulation	10

Standby Option

Front Panel	10
Operation	10
Transfer Switching Speed	11
Digital Voltmeter Option	11

Battery Charger

Overview	12
Battery Terminology	12
Battery Charger Controls	13

Theory of Operation

Stage One - Bulk Charge (Constant Current)	16
Stage Two - Absorption (Constant Voltage)	17
Stage Three - Float/Maintenance (Constant Voltage)	17
Equalization Stage	17

Batteries

Selection	18
Maintenance	20

Sizing	21
Hookup Configurations	22

Installation

Environment	24
-----------------------	----

AC Wiring

Overview	25
AC Connections	25
Ground Fault Interrupters	26
Important Precautions	26

DC Wiring Connections

Safety Instructions	28
DC Disconnect	28
Battery Cable Connections	28
Battery Cable Sizing	30

Marine Installations

Marine Mounting	30
Shore Power Connection to Boat's Main Panel and Grounding System	31
Galvanic Corrosion & Electrolysis	33
Connection of Shipboard Sources of AC Power to the Boat's Wiring System	33

Installation Diagrams

Marine/RV Installation with Single AC Panel	36
Marine/RV Installation with AC Sub Panel	37
Renewable Energy Installation	38
Inverter with Single AC Panel and External Relay	39
Inverter with Sub Panel and External Relay	40
External Transfer Relay Details	41
Standby Inverter with External Relay	42

Troubleshooting

Troubleshooting Guide	43
---------------------------------	----

Applications

Resistive Loads	44
Inductive Loads	44
Problem Loads	45

Technical Information

Design Goals	47
Specifications	49
Options	50

Performance Graphs

Load Capacity vs. Time	52
Power vs. Efficiency	53
Maximum Regulated Power vs. Battery Voltage	54
Maximum Loads vs. Temperature	55
Battery Charge Rate vs. Peak Input Voltage	56

Tables

Table 1- Battery Drain vs Loads	57
Table 2 - Metric to English Wire Size	58

Warranty Information

Limited Warranty	i
Warranty Procedure	ii

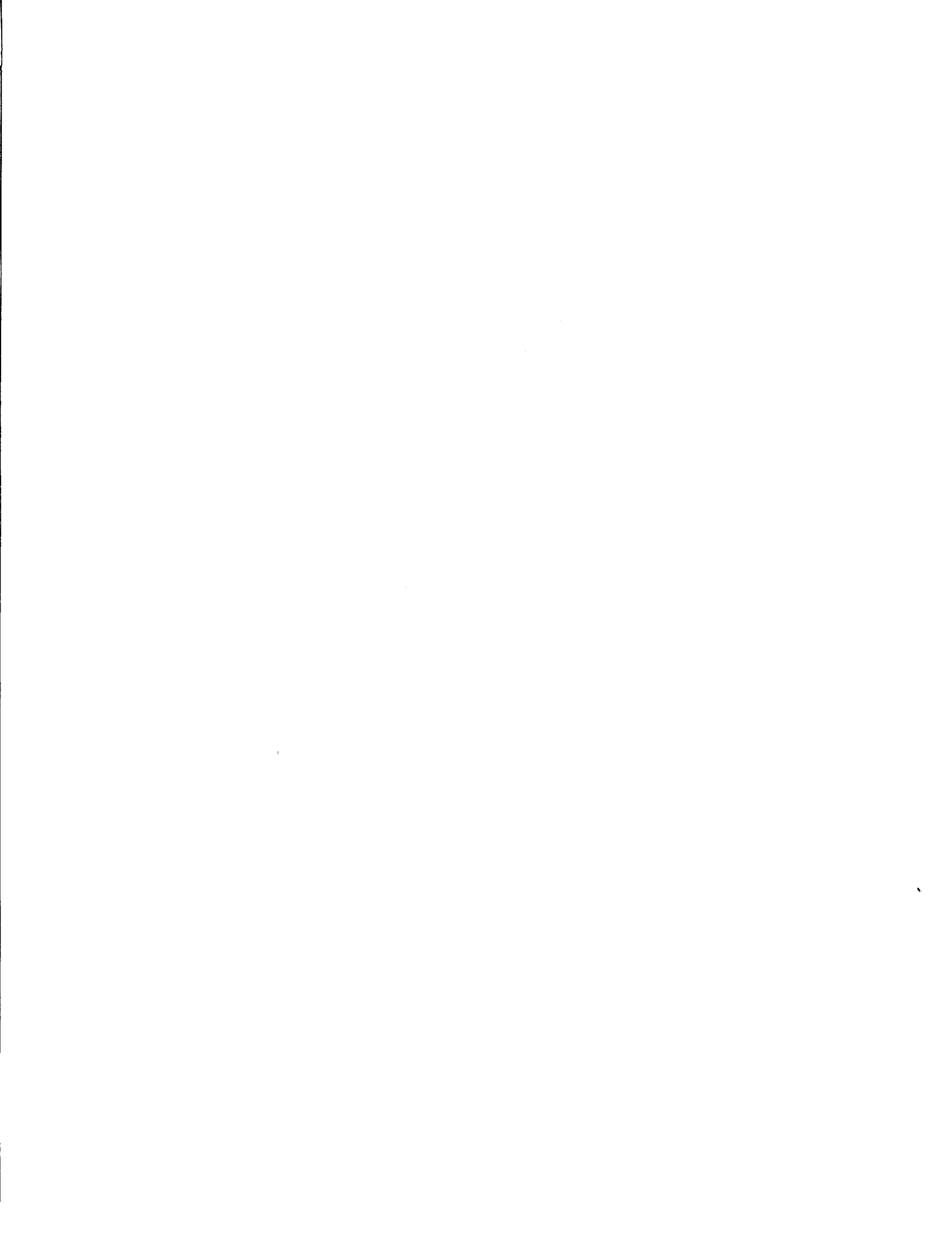

OTHER PRODUCTS AVAILABLE FROM TRACE ENGINEERING

RC-2000 Digital Voltmeter

Four-function, flush-mounted control panel can be placed up to 50 feet away from a 2500 series inverter. Once installed, the inverter can be turned on and off from the RC-2000. Four character digital readout is provided for: Battery Voltage, Charge Rate (Amps, Generator Frequency (Hz), and Peak Voltage of the AC source. In addition LED indicators provide: ON/OFF Status, Search Mode, AC Present and Error Conditions. TRACE also offers the more basic RC-2 which offers just the LED indicator.

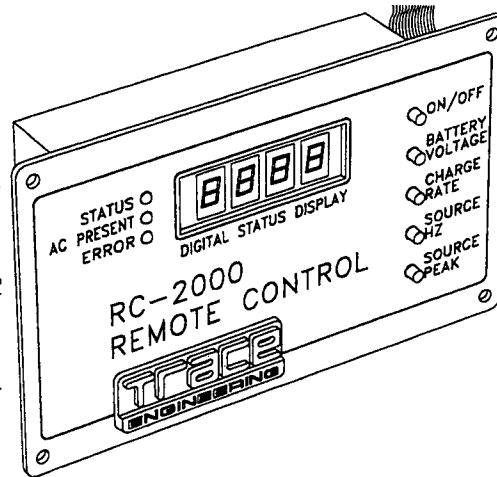

Stacking Interface (SIB)

Allows two like 2500 Series inverters to be paralleled for double the AC output power. If both units have the battery charger option, the charging capability is also doubled.

C30A Solar Charge Controller

Controls the charge received by the batteries from a solar array. It is rated at 30 amp capacity and has box terminals that will accept up to #4 AWG wire. The C-30A also features self-configuration for 12 or 24 volt VDC systems. An automatic disconnect feature prevents battery drain by disconnecting the solar array under low light conditions.

C30 Load Controller

The C30 can be manually set to operate at 12 or 24 volts as either a charge controller or DC load disconnect. As a charge controller, both high battery disconnect and low battery re-connect levels are user adjustable. As a load controller, both high battery re-connect and low battery disconnect are adjustable. The C30 is rated at 30 amps and uses box terminals that will accept up to #4 AWG wire.

Battery cables

Are available from Trace in various lengths to ensure maximum power from the inverter and batteries.

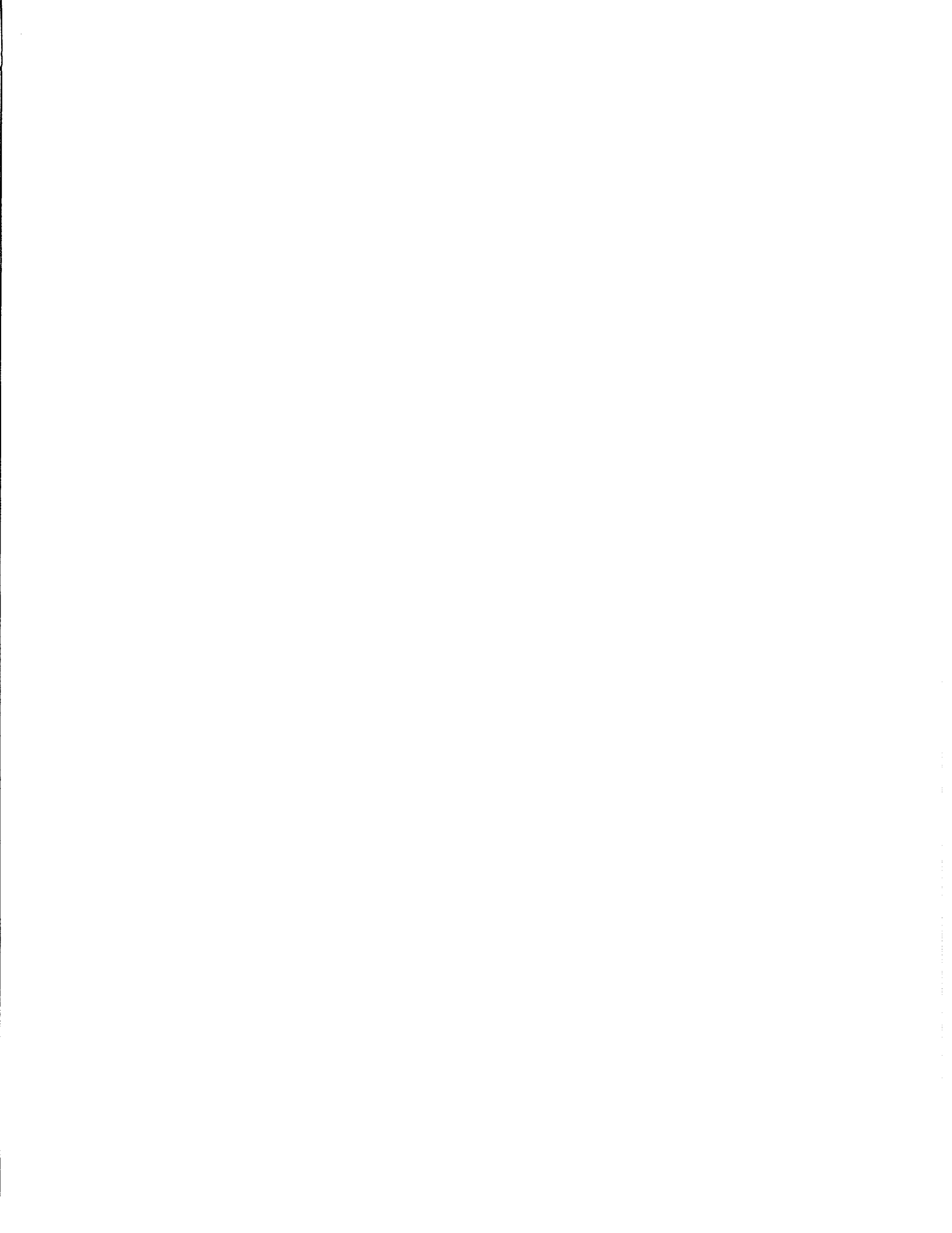

IMPORTANT SAFETY INSTRUCTIONS

SAVE THESE INSTRUCTIONS

This manual contains important safety and operating instructions as prescribed by ANSI/UL specifications for inverters used in marine, RV and residential applications. This manual covers inverters and inverter/chargers models: U2512, U2624, U2232, U2536 and U2548 Residential/Commercial series and U2512M, U2624M and U2232M Marine series.

The entire U2500 family of inverters is ETL listed to the general UL specification 1778 for electronic power inverters. The U2500M series is additionally listed to UL1236, UL458 and meets ABYC standards for marine use. All 12VDC and 24 VDC versions of both U2500 and U2500M inverters are listed to UL458 for RV/Motorhome use.

General Precautions

1. Before using the charger/inverter, read all instructions and cautionary markings on (1) the charger/inverter and (2) the batteries.
2. CAUTION- To reduce risk of injury, charge only deep cycle lead acid, lead antimony, lead calcium and gell cell type rechargeable batteries. Other types of batteries may burst causing personal injury and damage. Do not use battery charger for charging dry-cell batteries that are commonly used with household appliances. These batteries may burst and cause injury to persons and damage property.
3. Do not expose charger/inverter to rain, snow or moisture.
4. Use of an attachment not recommended or sold by TRACE ENGINEERING may result in a risk of fire, electric shock, or injury to persons.
5. Make sure wiring is located so that it will not be stepped on, tripped over, or otherwise subjected to damage or stress.
6. Do not operate the charger/inverter with bad wiring - replace immediately.
7. Do not operate charger/inverter if it has received a sharp blow, been dropped, or otherwise damaged in any way. Take it to a qualified service center for inspection and test.
8. Do not disassemble the charger/inverter; take it to a qualified service center when service or repair is required. Incorrect re-assembly may result in a risk of electric shock or fire.

9. To reduce risk of electric shock, disconnect all wiring before attempting any maintenance or cleaning. Turning off controls will not reduce this risk.
10. **WARNING - WORKING IN VICINITY OF A LEAD ACID BATTERY IS DANGEROUS. BATTERIES GENERATE EXPLOSIVE GASES DURING NORMAL OPERATION.**
11. NEVER charge a frozen battery.
12. If necessary to remove battery from vehicle to charge, always remove grounded terminal first. Make sure all accessories in the vehicle are off, so as not to cause an arc.
13. Be sure area around battery is well ventilated while battery is being charged. Gas can be forcefully blown away by using a piece of cardboard or other nonmetallic material as a fan.
14. Clean battery terminals. Do not allow corrosion to come in contact with eyes.
15. Add distilled water in each cell until battery acid reaches level specified by battery manufacturer. This helps purge excessive gas from cells. Do not overfill. For a battery without cell caps, carefully follow manufacturer's recharging instructions.
16. Study all battery manufacturer's specific precautions such as removing cell caps while recharging and recommended rates of charge.
17. **FOLLOW THESE STEPS WHEN BATTERY IS OUTSIDE VEHICLE. A SPARK NEAR THE BATTERY MAY CAUSE BATTERY EXPLOSION. TO REDUCE RISK OF A SPARK NEAR BATTERY:**
 - A. Check polarity of battery posts. POSITIVE (POS,P,+) battery post usually has a larger diameter than NEGATIVE (NEG,N,-) post.
 - B. Attach an insulated battery cable at least 24 in. long to the NEGATIVE (NEG,N,-) post. Size in accordance with chart on pg. 29.
 - C. Connect POSITIVE (RED) charger battery cable terminal to the POSITIVE (POS,P,+) post of battery.
 - D. Position yourself at the free end of cable as far away from battery as possible, then connect NEGATIVE (BLACK) charger battery cable to the charger.
 - E. Do not face battery when making final connection.
 - F. When disconnecting charger, always do so in reverse sequence of connecting procedure, and break first connection while as far away from battery as practical.

G. When a Residential/Commercial Series model is used to charge a marine battery, the battery must be removed and charged on shore. To charge it on board requires equipment specially designed for marine use.

- 18.** EXTERNAL CONNECTIONS TO CHARGER SHALL COMPLY WITH THE UNITED STATES COAST GUARD ELECTRICAL REGULATIONS (33CFR1833, SUB PART 1).
- 19.** No terminals or lugs are required for hook-up of the AC wiring. AC wiring should be 10 (AWG) gauge 90 degree C copper wire. Units supplied with the optional STANDBY feature should use 6 (AWG) gauge 90 degree C copper wire. Battery cables must be rated for 105 degree C and should be 2/0 (AWG) gauge (welding cable). A crimped and soldered lug with a 5/16 hole attached to the battery cable is required for connection to the inverter/charger.
- 20.** Torque all AC wiring connections to 20 inch pounds. Torque all DC cable connections to 12 foot pounds.
- 21.** Symbols used in this manual and on the inverter/charger are:

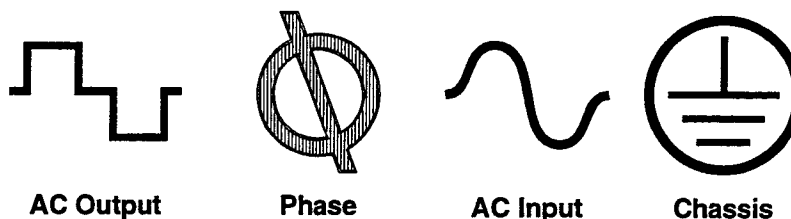

- 22.** Tools required to make AC wiring connections: Wire strippers 1/2", (13MM) open end wrench or socket, Philips screw driver #2, Slotted screw driver 1/4" (6MM) blade
- 23.** This inverter/charger is intended to be used with a battery supply of nominal voltage that matches the last two digits of the inverter model number, eg. 12 volt with a 2512.
- 24.** Instructions for wall or ceiling mounting: See mounting instruction section of this manual. NOTE: For marine applications, do not use the key hole mounting slots. For battery installation and maintenance: read the manufacturer's installation and maintenance instructions prior to operating.
- 25.** No AC or DC disconnect switch is provided as an integral part of this unit. Both AC and DC disconnects must be provided as part of the system installation. See SYSTEM SAFETY WIRING REQUIREMENTS section of this manual.
- 26.** No overcurrent protection for the battery supply is provided as an integral part of this unit. Overcurrent protection of the battery cables must be pro-

vided as part of the system installation. See SYSTEM SAFETY WIRING REQUIREMENTS section of this manual.

27. No overcurrent protection for the AC output wiring is provided as an integral part of this unit. Overcurrent protection of the AC output wiring must be provided as part of the system installation. See SYSTEM SAFETY WIRING REQUIREMENTS section of this manual.
28. **GROUNDING INSTRUCTIONS** - This battery charger should be connected to a grounded, metal, permanent wiring system; or an equipment-grounding conductor should be run with circuit conductors and connected to equipment-grounding terminal or lead on battery charger. Connections to battery charger should comply with all local codes and ordinances.

PERSONAL PRECAUTIONS

1. Someone should be within range of your voice or close enough to come to your aid when you work near lead-acid batteries.
2. Have plenty of fresh water and soap nearby in case battery acid contacts skin, clothing, or eyes.
3. Wear complete eye protection and clothing protection. avoid touching eyes while working near batteries.
4. If battery acid contacts skin or clothing, wash immediately with soap and water. If acid enters eye, immediately flood eye with running cold water for at least 10 minutes and get medical attention immediately.
5. NEVER smoke or allow a spark or flame in vicinity of battery or engine.
6. Be extra cautious to reduce the risk of dropping a metal tool onto batteries. It might spark or short-circuit batteries or other electrical parts that may cause an explosion.
7. Remove personal metal items such as rings, bracelets, necklaces, and watches when working with a lead-acid battery. A lead-acid battery can produce a short-circuit current high enough to weld a ring or the like to metal, causing a severe burn.

Operation

Front Panel

Shown below is the front panel for the standard inverter without the optional battery charger. The front panel for inverters with the optional battery charger is shown in the chapter *Standby Option*.

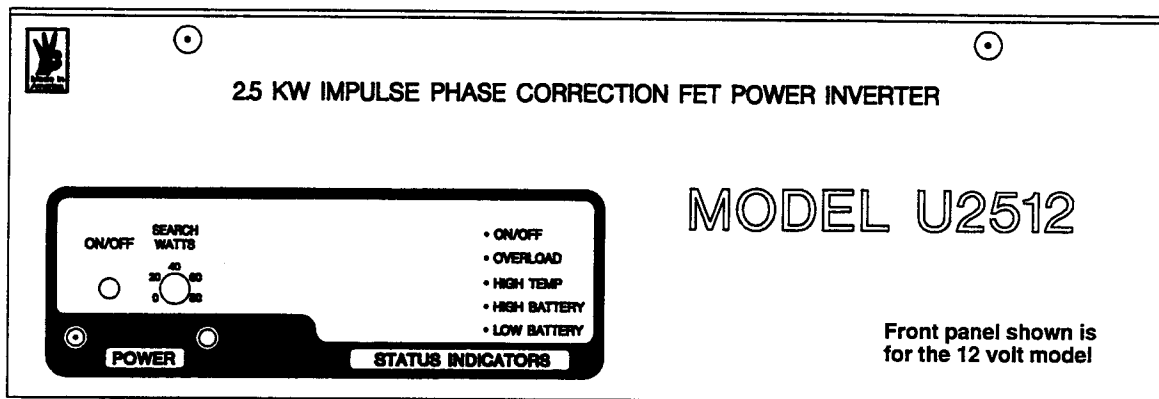

Figure 1, Front Panel for Standard Inverter

Two controls are provided with the standard unit. Located on the left of the panel is the momentary ON/OFF switch. Next to it is the SEARCH WATTS control used for adjusting the sensitivity of the search mode circuit. Behind the Lexan front panel, on the main circuit board there is a vertical row of five LED's (light emitting diodes). The top LED indicates a change in ON/OFF status. The remaining four report on any activation of the protection circuits.

Start-up

When first connected to batteries, the inverter will be in the off state. Whenever the batteries are connected, the momentary power switch must be pressed once to turn the inverter on. Subsequently pressing the on/off switch alternately turns the inverter on and off. An amber LED indicator lamp lights when the inverter is on. When the inverter is in its search mode the amber LED will blink. While the inverter is delivering full output voltage (not in the search mode) the amber LED is on solid.

Search Mode Control

The Series 2000 inverters feature an adjustable search mode circuit. It minimizes power drain by reducing the inverter's output to small test pulses when there is no load connected. These pulses are used to detect the presence of a

load. When a load is detected the inverters' output goes to full voltage. The sensitivity of the detection threshold is adjustable. Turning the SEARCH WATTS control clockwise decreases the sensitivity. Turning the control full counter-clockwise defeats the search mode feature.

Example: With the SEARCH WATTS control set at 40, a 50 watt load will bring the unit to full output voltage, however a 30 watt load will leave the inverter in its energy saving search mode state. If the sensitivity is increased by setting the control to 10, a 20 watt load will bring the inverter out of the search mode, while a 5 watt load will not.

When in the search mode, the amber power LED will blink and the inverter will make a ticking sound. At full output voltage, the amber power LED will burn steadily and the inverter will make a steady humming sound. When the inverter is used as an uninterruptable power supply the search mode function should be defeated.

A neon nightlite can also be used as a good indicator to determine if the inverter is in search mode. Simply plug the light into any AC outlet. When the inverter is in the search mode the light will blink. If the inverter is running a load, the light will be solid.

Exceptions: (Murphy's Law) Unfortunately, things don't always work the way the manual says they will.

Example A: If the SEARCH WATTS control is set at 40 and a 30 watt incandescent light is turned on, the inverter will detect the light. The light is a bigger load than 40 watts when its filaments are cold. When the light gets bright the filaments heat up and the light becomes a 30 watt load. Since this is below the control setting of 40, the inverter will not detect it and the light will go out. And so on and so forth.

Example B: If the SEARCH WATTS control is set at 30 and a 40 watt florescent light is turned on, the inverter will not detect the light. The light presents a smaller load than 30 watts until the gas in the florescent tube ionizes,

Example C: There are some appliances that draw power even though they are turned off. TVs with instant on circuits, microwave ovens with digital displays and VCRs are examples. These loads present a dilemma. If the sensitivity is set higher than the combination of these loads, then an auxiliary load must be used to bring the inverter out of the search mode before the appliances can be turned on. If the sensitivity is set lower then this combination of loads, the loads will be left on and will put an additional drain on the batteries. (Three such 15 watt loads would amount to an additional 90 amp/hours per 24 hours in a 12 VDC system.) One solution is to turn these items off at the wall. Use an extension cord with a rocker switch, a switch at the outlet, or the appropriate circuit breaker.

Battery Over Discharge Protection

Unique to Trace Inverters is the Battery Over Discharge Protection (BOD) circuit. Its purpose is to protect the batteries from being over-discharged. This circuit monitors both the current being drawn by the inverter and the battery voltage. Battery voltage alone is not an accurate indicator of battery condition. The internal resistance of a battery causes its output voltage to drop when the battery is delivering current. The smaller the battery the greater the voltage drop for a given load. This battery voltage drop due to load is not an indicator of the battery's state of charge. The Trace "load compensated" BOD circuit uses information about the size of the battery bank and the load current to derive a corrected battery voltage. If the BOD circuit determines that the battery condition is low, the inverter turns off and requires a manual restart.

BATTERY PROTECTION CONTROL SETTINGS						
Battery Bank / Amp Hours			System Voltage	Cut Out Voltage		
Min	Center	Max		Min	Center	Max
200	800	infinity	12	9.6	11.1	12.5
100	400	infinity	24	19.2	22.1	25.1
75	300	infinity	32	25.6	29.5	33.4
67	237	infinity	36	28.8	33.2	37.6
50	200	infinity	48	38.4	44.3	50.2

The BOD circuit is user adjustable for low battery turn off voltages and battery bank sizes. Controls are located on the left front corner of the top of the inverter. Battery bank size may be varied from 2400 watt/hrs to infinity. Center position on the control is 9600 watt/hours (9600 watt/hours is 800 amp hours at 12 volts, 400 amp hours at 24 volts, etc). Compensated battery protection voltage may be varied from 1.6 to 2.09 volts per cell (9.6 to 12.54 volts on a 12 volt battery). Inverters are shipped from the factory with the **least** sensitive settings (2400 watt/hours and 1.6 volts per cell). The controls will have to be adjusted in order to activate the circuit.

Improper adjustment of the BOD circuit typically causes the inverter to turn off before the batteries are sufficiently discharged. The BOD circuit can be defeated by adjusting the voltage and bank size to their lowest settings. If the BOD circuit is defeated the inverter itself is protected from low battery voltage conditions by an additional low battery protection circuit.

Protection Circuitry

The inverter will **automatically** restart itself from the following overload conditions: low battery, high battery, shorted output, over current, over temperature.

The inverter will turn itself off and require a **manual** restart under the following conditions: (1) if it is put to the ultimate test and has its AC output connected to public power; (2) if an attempt is made to start a very large motor; (3) if it encounters a load large enough to enable the protection circuit and reduce the output wave form for approximately 15 seconds (a prolonged short circuit).

Indicator Lamps

There are 5 LED indicator lamps on the **Series 2000** units that monitor the inverter's operation. These LED's are viewed thru the lexan front cover and are located slightly to the left of center. The **On/Off** LED is amber. The rest are red. The standby option adds three more LED's on the right side of the front panel. Their operation is explained in the battery charger chapter.

- **On/Off** - This LED lights when the inverter is on. If the inverter is under load, this LED will burn steadily; in its search mode the ON/OFF LED will be flashing. The ON/OFF switch also activates the battery charger function.
- **Overload** - This LED lights when the load being run demands more current than the inverter can safely supply. If the lamp is on while a load is running, it implies a reduced output voltage. Since the protection circuit is temperature compensated, a large load that runs satisfactorily when the unit is cold may begin to trip the protection circuit and light the overload lamp when the inverter is warm. If an overload condition exists for more than 20 to 30 seconds, the inverter will turn itself off. To restart the inverter, press on/off switch once.
- **Over Temperature** - This LED indicates an over-temp condition. If the temperature of the power transformer or the heat sink rises above its designed operating limits, the inverter will shut off and automatically restart after a sufficient cooling period.
- **Low Battery** - There are two low battery protection schemes in this inverter (1) the Battery Over Discharge (BOD) circuit which protects the batteries, and, (2) the Low Battery Voltage (LBV) circuit which protects the inverter. If the low battery voltage (LBV) circuit is activated, the inverter shuts down its AC output, but all other circuits remain active. It will remain in this state with the Low Battery LED lit until battery voltage rises to a safe level. At this point the inverter resets itself and again picks up the AC load. If the battery protection circuit (BOD) is activated, the inverter will turn off altogether, and consequently no LED's will be lit. The inverter must be manually restarted from this condition.

Note: When a Standby model inverter is shut down due to a low battery condition, the battery charger will also be disabled. In this situation, a small charge from a stand-alone charger will be required to bring the battery to a high enough voltage for the inverter/charger to resume operation.

- **High Battery** - If battery voltage rises above the high voltage protection point, the inverter shuts down and lights this LED. When the voltage has dropped to a safe level, it restarts. (See specifications section for these voltages.)

Theory of Operation

Waveform

The output waveform of the inverter is referred to as a modified sine wave. This waveform is suitable for a wide variety of applications. Induction motors (i.e. refrigerators, drill presses), resistive loads (i.e. heaters, toasters), universal motors (i.e. hand tools, vacuum cleaners) as well as microwave ovens and computers are all suitable loads.

The waveform could be more accurately described as a pulse width modified squarewave. The accompanying *Figure 2* shows the relationships between squarewave, sine wave and modified sine wave formats.

Regulation

The inverter is RMS voltage regulated. RMS regulation ensures that resistive loads will always have the same amount of power delivered to them as battery

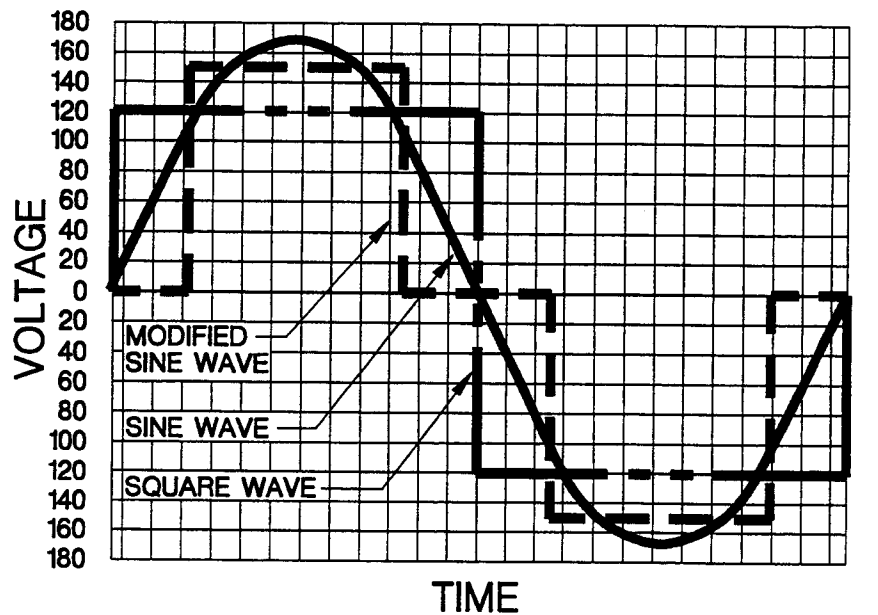

Figure 2, Comparison of Output Waveforms

voltage changes. Regulation is achieved by varying the width of each pulse. Peak voltage is the product of the battery voltage times the turns ratio of the inverter's power transformer and is therefore not regulated.

Standby Option

Front Panel

Shown below is the front panel for units with the Standby Option which includes an internal battery charger option and automatic transfer switch.

Units with the standby option have four additional momentary switches on the left side of the front panel. These are for the Digital Voltmeter option. If your unit is not equipped with the DVM option, these switches are not functional. The right side of the front panel has seven adjustable controls for setting battery charger parameters, and a recessed momentary switch for initiating an equalization charge. Also provided on the front panel are three test and one ground point for the precise adjustment of voltage settings.

Operation

The standby option adds an internal battery charger and automatic transfer relay. This allows the unit to operate as either a battery charger or inverter (but not both at the same time). An external source of AC power (eg, shore power or generator) must be supplied to the inverter's AC input in order to allow it to operate as a battery charger. When the unit is operating as a charger, its AC output is powered by the external source (i.e. generator or public power).

The inverter automatically becomes a battery charger whenever AC power is delivered to its AC inputs. There is a 15 second time delay from the time the inverter senses that AC is present at its input and when the transfer is made. This delay is built in to provide time for a generator to spin-up to a stable voltage and avoid relay chattering. While in the battery charger mode the inverter's AC input is internally connected to the inverter's AC output. 60 Amps is the maximum power that can be handled by the inverter's internal wiring and transfer relay. Of the available 60 amps, 30 can be passed directly from the AC input to AC output. The remaining 30 amps is available to the charger. During heavy charging a maximum of 20 amps will be consumed by the charger.

Transfer Switching Speed

While this inverter is not designed specifically as a uninterruptable power supply (UPS) system, its transfer time is normally fast enough to hold up computers. The transfer time is approximately 35 milliseconds when switching from charger to inverter mode.

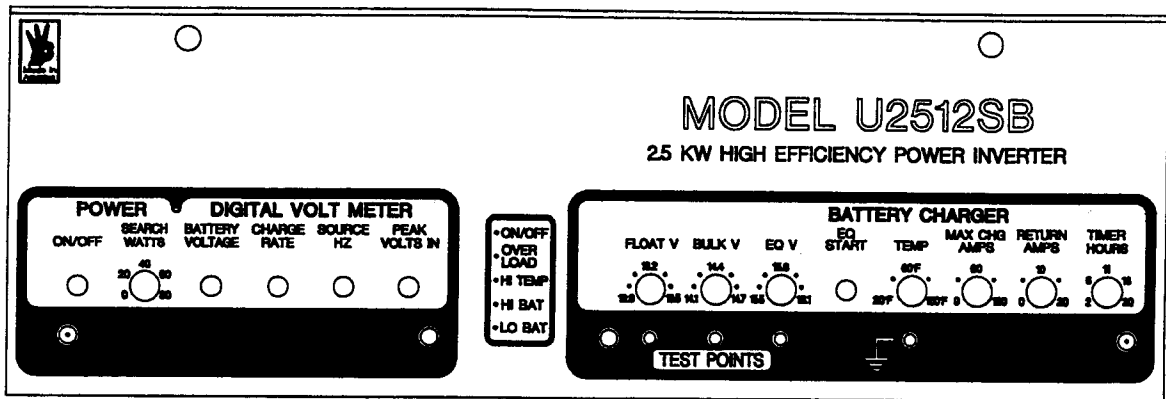

Figure 3, Front Panel for Standby Models

Front panel shown reflects voltages for the 12 volt model

When switching from inverter to charger, the inverter waits approximately 15 seconds to ensure the AC source is stable (generator up to speed) and then makes the transfer in approximately 30 milliseconds.

PC Magazine has run tests that indicated a transfer time of 100 milliseconds will normally hold up the present generation of PC's.

Digital Voltmeter Option

A four function digital voltmeter is standard on all RV/Marine Series inverters. This option is available on the AE/UPS Series units that are equipped with the standby option. It can be factory or user installed.

Digital Voltmeter Functions

- **Battery Voltage** - Reads average battery voltage while in standby or inverter mode. Operates with the inverter on or off.
- **Charge Rate** - Reads average battery charge rate in amps.
- **Source Hz** - Reads the frequency of the external AC source which is supplying the power to charge the batteries (public power or generator).
- **Peak Volts In** - In order for the battery charger to deliver its rated current, it must be supplied with sufficient peak AC volts. (approximately 164 volts on a 120 VAC unit) If the peak voltage is above 200 volts the meter will read "OFL". This condition is dangerous to household electronic appliances - TV's, VCR's, stereo's, etc. Correct this problem at the generator.

Installation By User

Disconnect the battery just in case you drop a screw. Touch the heat sink with your finger to eliminate any static charge. Remove the lexan front cover. Orient the DVM board so the digital readout is at the top. The female connector on the DVM board aligns with the vertical row of pins located 3 inches from the left

edge of the mother board. Notice the 4 plastic standoffs that you will be snapping the DVM board to. Align the connectors carefully, then gently press the DVM board onto the main PC board. Snap the DVM board onto the plastic

standoff. Reconnect the battery - CAREFULLY! Don't be surprised when an arc is drawn as you make the connections.

Battery Charger (standby option only)

Overview of Battery Charger Operation

The charger is a powerful and sophisticated constant current, voltage limited design that normally operates in three stages. During the initial, "Bulk Charge" stage, the unit charges at a constant current causing the battery voltage to rise. A constant voltage, "Absorption" stage begins after the battery voltage reaches the bulk charge voltage. During this second phase, the charge rate is gradually reduced holding the battery voltage constant. The third, or "Float" stage is initiated when the current required to hold the batteries at the bulk charge voltage has tapered to a low level. At this point, the battery voltage is allowed to fall to a float voltage, where it is maintained until another charge cycle is initiated.

Users well rounded in batteries and battery charging can optimize charger operation through fine tuning of the many user adjustable charge controls. Most users will want to accept factory default settings.

Battery Terminology

A description of the battery charger operation requires the use of terms with which you may not be familiar. The following terms will be referred to in the description of the battery charger operation.

- **Electrolyte** - Typically a mixture of water and sulfuric acid, it is commonly referred to as battery acid.
- **Plates** - Originally made of lead, they are now made of lead oxide. Plates are the part of the battery that collects current and are connected to the terminals. There are several plates in each cell, each insulated from the other by separators.
- **Sulfating** - As a battery discharges, its plates are progressively covered with lead sulfate. During recharging, the lead sulfate is removed from the plates and recombines with the electrolyte. If the lead sulfate remains on the plates for an extended period of time (over two months), it hardens, and recharging will not remove it. This reduces effective plate area and the battery capacity is diminished.
- **Stratification** - Over time the batteries' electrolyte (liquid) tends to separate. The electrolyte at the top of the battery becomes watery while at the bottom it becomes more acidic. This effect is corrosive to the plates.
- **Deep Cycle** - A deep cycle occurs when a battery has been discharged such that less than 20% of its capacity remains (80% discharge).

Battery Charger Controls

A comprehensive set of controls are provided with the Standby Option's internal battery charger. This makes it possible for qualified users to tailor the charging characteristics for various types of batteries, environments and special situations.

If this array of controls seems formidable to you, use the factory default settings. Resetting the charger to the factory positions is easily accomplished by turning all controls to their 12 O'clock position.

Max Chg Amps

This sets the maximum charge rate in amps. The highest charge rate recommended is determined by dividing the battery bank's amp hour capacity by a factor between 3 and 5 (3 for gel cell - 5 for lead acid). Setting the MAX CHG AMPS at the highest recommended level is best when the objective is to charge the batteries as quickly as possible. A much lower setting can be used in installations where AC power is typically available for periods of several hours. For example: there is more than sufficient time for a 400 amp/hr battery bank to be recharged in 24 hours at a 25 amp setting - $25 \text{ amps} \times 24 \text{ hours} = 600 \text{ amp/hrs}$.

Bulk V

This sets the maximum voltage (bulk charge voltage) at which the batteries will be charged during a normal charging cycle. The normal range is 2.367 to 2.4 volts per cell. For a 12 VDC battery (6 cells) this is 14.2 to 14.4. Liquid electrolyte batteries are usually set to the higher voltage, while gel cell batteries are set to the lower.

Return Amps

This setting is used by the charger to determine when it should change to the float stage. Normal setting is from 2% to 4% of the battery capacity, i.e. a 200 amp battery bank would call for a setting of 4 to 8 amps.

Note that the charger will also deliver current to drive any external DC loads that may be connected during the charge cycle. The current requirements of the DC loads could keep the charge rate from falling to a low enough level to initiate the float stage. If significant DC loads are anticipated during charging, the RETURN AMPS setting can be set higher to compensate.

Float V

This control sets the float voltage, i.e. the voltage at which the batteries will be maintained after they have been charged. The factory setting is based on 2.2 VDC per cell or 13.2 VDC for a 12 VDC battery. A range of 13.2 - 13.4 is appropriate for most sealed and non-sealed batteries.

Timer Hours

TIMER HOURS is a safety feature that ensures that abnormal conditions will not cause the charger to hold the batteries at high voltages for prolonged periods of time. The range of adjustment is 2 to 20 hours. This control limits the maxi-

imum amount of time that the charger is allowed to hold the batteries in the Bulk Charge mode. It also sets the maximum duration of the Equalize mode.

EQ Start

This recessed momentary switch initiates the equalization cycle. During equalization, charging continues until the batteries reach the voltage setting of the EQ VOLTAGE control. Once this voltage is attained, equalization is terminated and the charging voltage falls to the float voltage. Equalization will also be terminated on a time basis if the time indicated on the TIMER HOURS control is exceeded. Equalization can be manually terminated by pressing the EQ START a second time.

Caution: DC loads should be disconnected from the batteries during equalization to protect appliances from high battery voltage.

Caution: Equalization was designed for use on standard liquid electrolyte (lead-acid) batteries. If you have sealed or gel cell batteries, do not use the Equalization function without first checking with the manufacturer.

If batteries are being used on a daily basis they should be equalized every one to two months.

The battery voltage will rise higher than the high battery protection threshold during equalization. This will light the high battery protection LED. It is not harmful to the inverter. The high battery protection inhibits the output of the inverter (not the charger) to eliminate the possibility of damage to AC loads if the inverter were operated at very high battery voltages. If the optional RC2 remote control is installed it will indicate an error condition by flashing its indicator lamp.

EQ Voltage

This control sets the termination voltage for battery equalization cycle.

Temp

The optimum voltage for the various charging stages is temperature dependent. As temperature decreases the proper voltages for each charge stage need to be increased. All charge voltage settings can be re-scaled for ambient temperature. Adjustment is made by simply setting the TEMP control to the temperature of the environment where the batteries are stored. For the technically minded, the compensation slope based on cell voltage is -2.17 mv per degree F. per cell.

The front panel markings for BULK V , FLOAT V and EQ V points will correspond to the actual control voltages **only** when the TEMP control is set at 60° F. When the TEMP control is varied from the 60° F. norm, the temperature compensation circuitry automatically re-scales the control voltage points, and the front panel settings no longer reflect the actual voltages used by the charger to pro-

gress through its charge stages. The actual control voltage can be read (in cell voltage) at the TEST POINTS.

For example: with a 12 VDC inverter, if the FLOAT V is set at 13.2 VDC and the TEMP is set to 40 degrees, the actual float voltage will be 13.46 F. This is derived as follows: $13.2 + 6 [(-20) \times (-.00217)]$.

Charge Indicator LED's

Three LED indicators are located on the front panel for monitoring battery charger status.

- **Yellow LED** - Located above the BULK V control, this LED indicates that the charger is on. If no other battery charger LED's are lit, it also indicates that the charger is in the Bulk Charge Stage.
- **Green LED** - Located above the FLOAT V control, this LED indicates that the charger is in the Float Stage.
- **Red LED** - Located above the EQ V control, this LED indicates that the charger is in the Equalize Stage.

Test Points

Access to three test points and one ground point are provided on the front panel. These may be used with an accurate voltmeter for precisely setting the float, bulk and equalize voltages. The test points are located below their respective voltage controls.

To use the test points, the ground/negative/black voltmeter probe is placed at the ground point and the positive/red probe is placed at the position for the desired voltage. Readings at these points are in cell voltage and include the effects of the temperature compensation circuit. They will correspond to the dial scale **only** when the TEMP control is set at 60⁰F.

Theory of Operation

The battery charger in standby models normally charges in three stages - bulk, absorption and float - to provide rapid and complete charge cycles without undue battery gassing. A manually operated equalize stage is provided for periodic battery maintenance.

Stage One - Constant Current/Bulk Charge

This stage is initiated in two ways:

- When AC is applied to the AC input of the inverter.
- When the battery voltage is less than the float voltage by at least .040 volts times the number of cells. In a 12 VDC system this is .240 volts.

Example: With FLOAT V set to 13.2 and TEMP set to 60⁰F., a 12 volt inverter will shift from Float to Bulk stage at 12.96 volts.

Stage one charges the batteries at a constant current. The level of charge for this phase is set using the MAX CHG AMPS control on the front panel. The constant current phase is terminated when the batteries reach the bulk charge voltage. During this stage only the yellow LED is lit.

Caution: Do not charge your batteries at higher voltages and/or currents than their manufacturers recommend. This is a very powerful charger. If used incorrectly it may damage your batteries.

The maximum charge rate of the battery charger is dependent upon the peak AC voltage available. Because a battery charger uses only the top portion of the input sine wave, small variations in peak voltage result in large variations in the amount of energy to the charger. This charger's output is rated on the basis of public power input which has a peak voltage of 164V (230V AC power has a peak voltage of 330).

It takes a powerful AC generator set to maintain the full 164 volt peak while delivering the current necessary to operate the charger at its maximum rate (typically 6kw). Smaller generators will have the tops of their wave form clipped under such loads. Running at these reduced peak voltages will not harm the charger, but it will limit the maximum charge rate. Large auxiliary AC loads may exacerbate this problem.

Stage Two - Constant Voltage/Absorption

Absorption is initiated when the Bulk Voltage setting is reached. At this point the charge current begins to taper off at whatever rate is required to hold the voltage constant. Only the yellow LED is lit during this stage. The absorption phase is terminated in one of two ways.

- 1 - Normally, as the charge cycle progresses, the current required to hold the battery voltage constant gradually reduces. When this current equals the RETURN AMPS setting, the voltage is allowed to fall to the FLOAT V (float voltage) setting - stage three.
- 2 - If there are DC loads on the batteries, the current may never fall to a level low enough to initiate the float voltage stage. An adjustable timer is used to ensure that the battery voltage does not remain indefinitely at the Bulk Charge Voltage. The timing circuit is activated by the onset of stage two, it terminates stage two if the charge current does not reach the RETURN AMPS setting before the TIMER HOURS setting is reached..

Stage Three - Float Voltage

The purpose of stage three is to maintain the batteries at a voltage that will hold full charge but not gas the batteries. The charger remains in the float stage until either the charger is turned off or the battery voltage falls below the float voltage. During this stage the yellow and green LED's are lit.

Note: If sufficient DC loads are placed on the battery, the charger will deliver currents up to the Max Charge setting while maintaining the float voltage.

Equalization Stage

Periodically it is advantageous to charge liquid electrolyte batteries to a voltage high enough to gas the batteries. This removes the lead sulfate from the plates and stirs up the electrolyte that tends to stratify during normal operation. The equalize stage is initiated manually by pressing the EQ button on the front panel. During this stage the yellow and red LED's are lit. When the battery voltage reaches the Bulk Charge Voltage, the timer protection circuit is engaged. The EQ stage is terminated in one of three ways.

- 1 - The batteries reach the EQ Voltage setting as determined by the front panel control.
- 2 - The battery voltage has been above the Bulk Charge Voltage for a period of time equal to the time as set on the front panel TIMER HOURS control.
- 3 - Pressing the EQ START control a second time.

The battery voltage will rise higher than the high battery protection threshold during equalization. This will light the high battery protection LED. It is not

harmful to the inverter. The high battery protection inhibits the output of the inverter (not the charger) to eliminate the possibility of damage to AC loads if the inverter were operated at very high battery voltages. If the optional RC2 remote control is installed it will indicate an error by flashing its indicator LED.

CAUTION: The Equalization feature was designed for use with standard liquid electrolyte batteries. If you have sealed or gel cell batteries, do not use this feature without first checking with the battery manufacturer.

Batteries

Batteries come in different sizes, types, amp hours, voltages and chemistries. There are nearly as many descriptions of exactly how batteries should be charged as there are people willing to offer explanations. It is not possible here to discuss all aspects in detail. However, there are basic guidelines you can follow that will help in battery selection and ensure that your batteries are far better maintained than the majority.

Selection of Battery Type

Starting Batteries

These are designed for high cranking power, but not deep cycling. Don't use them. It does not hurt the inverter - they simply will not last long in a deep cycle application. The way they are rated should give you a good indication of their intended use. "Cold Cranking Amps" is a measure of the amperage output that can be sustained for 30 seconds.

Telephone Company Batteries

Second-hand telephone batteries are often available at far below original cost. They are sometimes used in remote homes successfully. Typically they are a lead calcium design. Therefore, they should not be cycled below 80% of their amp/hr rating. Keep this in mind when evaluating their amp/hr to cost ratio.

Deep Cycle Batteries

This is the type of battery best suited for use with inverters. They are designed to have the majority of their capacity used before being recharged. They are available in many sizes and types. The most common type is the non-sealed liquid electrolyte battery.

Non-sealed types have battery caps. The caps should be removed periodically to check the level of electrolyte. When it is low, distilled water should be added.

A popular and inexpensive battery of this type is the "golf cart" battery. It is a 6 volt design typically rated at 220 amp/hr, and costing about \$70-\$80.

Many systems use Trojan L16's. These are 350 amp/hr, 6 volts, and distributed by Interstate Batteries at a list of about \$185. They are 17 inches in height which may be troublesome in RV or marine installations.

8D batteries are available with either cranking or deep cycle construction. Since they are most commonly used to start truck engines, you should make sure you purchase the deep cycle version. Rolls and Surette make a very rugged but expensive 8D (800 deep cycles claimed). The 8D is typically rated at 220 amp/hrs at 12 volts.

If battery requirements are large, industrial grade 2 volt batteries are suitable. This is the type of battery used in fork lifts and submarines.

Sealed Gel Cell

Another type of battery construction is the sealed gel cell. They don't use battery caps. The electrolyte is in the form of a gel rather than a liquid which allows the batteries to be mounted in any position. The advantages are no maintenance, long life (800 cycles claimed) and low self discharge. The disadvantage is high initial cost. Typically \$450 to \$500 for an 8D.

While there are many manufactures of quality non-sealed batteries, there are only a few manufactures of gel cells. Sonnenschein, marketed as Prevailer, and the Dynasty by Johnson Controls are two.

NiCad and Nickel Iron (NiFe)

Trace inverters and battery chargers are optimized for use with lead acid batteries which have a nominal voltage of 2.0 volts per cell. NiCad/NiFe batteries have a nominal cell voltage of 1.2 volts per cell. The nominal voltage of a NiCad/NiFe battery bank can be made the same as a lead acid bank just by juggling the number of cells (10 cells for NiCad/NiFe vs 6 cells for lead acid both produce 12 volts nominal.) However, the NiCad/Nife battery bank will have a much higher operating voltage range. The following paragraphs offer alternative procedures for effective use of Trace inverters/chargers with these types of batteries.

On 24 volt systems, the easiest and most effective way to use NiCad/NiFe batteries with Trace inverters is to use nineteen cells in the battery bank instead of twenty. This will reduce the battery bank operating voltage to about the same level as a lead-acid bank, so standard charger settings can be used. This alternative works well so long as the DC loads are not voltage sensitive, eg., DC motors. Dropping a cell on 12 volt systems--going from 10 to 9--is not a recommended alternative.

A second option on either 12 or 24 volt systems is to adjust the Bulk Charge Voltage to its maximum setting (14.7 on a 12 volt system; 29.4 on a 24 volt system.) This will provide a complete charge, albeit at a slower rate than if a higher charge voltage (or lesser number of cells) were used.

A third option would be to use the Equalize function to charge the batteries. In this case, a bulk charge voltage more suitable to fast charging is available

through adjustment of the EQV dial to 15.5 volts for 12 volt system; 30.5 volts for 24 volt. The downside of this option is that the charge cycle would have to be initiated manually.

Regardless of option chosen, the Return Amps dial can be set to maximum scale (20 amps for 12 volt; 7.5 amps for 24 volt) since NiCad/NiFe batteries do not require an Absorption stage.

Float Voltage settings for NiCad/NiFe batteries should be 1.32 to 1.35 volts per cell (13.2 - 13.5 for 12 volt and 26.4 - 27.0 on 24 volt.)

Note: In alternative energy applications (solar, wind, hydro) DC charge controllers should be set to a level below the inverter high voltage cutoff point. (15.5 volts on a 12 volt system - 30.5 volts on a 24 volt system.)

Maintenance

If you have read the section "Theory of Operation", you already have a good idea of the stages of battery charging that combine to promote fast charging and ensure long battery life. Basically, there are four charger related considerations to properly care for your batteries.

- **Charge Rate** - The maximum safe charge rate is related to the size of your batteries. The battery bank capacity in amp/hours divided by 4 or 5 is appropriate for non-sealed batteries. Some gel cells can be charged at a rate as high as amp/hours divided by 3. Use the MAX CHG AMPS control to make this setting.
- **Charge Voltage** - The normal range based on cell voltage is 2.367 to 2.4 VDC. For a 12 VDC battery this is 14.2 to 14.4 VDC. Gel cell batteries are usually set to the lower figure, while non-sealed batteries are set to the higher. Use the BULK V control.
- **Float Voltage** - The batteries experience less gassing if they are maintained at a lower voltage than the voltage at which they are charged. Both sealed and non-sealed batteries can be set to a float charge of 2.2 VDC per cell. This is 13.2 for a 12 VDC battery. Use the FLOAT V control.
- **Equalization (Non-Sealed Batteries Only)** - Every month or two batteries may need to be "equalized." (A fancy term for over-charged.) Since the individual battery cells are not exactly identical, some may still have sulfate on their plates after a complete charge cycle. Or, if the batteries never receive a full charge, all plates will have sulfate left on them. If the sulfate remains on the plates for an extended period of time, it will harden and seal off a percentage of the plate area, reducing the capacity of the battery. By equalizing the batteries, all the sulfate is removed from the plates. Additionally, the gassing that results stirs up the electrolyte which tends to stratify. Stratification concentrates the sulfuric acid in the bottom of the cell while the top becomes watery. This corrodes the plates. To start the Equalization cycle simply press the EQ control.
- During equalization the battery voltage will rise above the inverter's high battery protection threshold. This will light the high battery

protection LED, but will not harm the inverter. If the RC/2 remote control is being used, its light will blink indicating an error condition. Both of these indicators were designed to warn of excessive battery input voltage when operating in inverter mode. They can be ignored when in battery charger mode.

- **CAUTIONS:** The Equalization feature was designed for use with the standard electrolyte batteries. If you have sealed or gel cell batteries, check first with the battery manufacturer before using this feature. DC loads should be disconnected before equalization to protect appliances from high battery voltage.
- **Temperature Compensation** - Temperature affects the optimum voltage values for the different charge stages. The TEMP control can be used to fine tune these voltages. Set it to the average ambient temperature that the batteries experience. Typically this control will be set seasonally.

Note that voltage settings on the dials will correspond to actual control voltages used by the charger only when the TEMP dial is set to 60⁰F. Adjusting the TEMP dial re-scales all control voltages.

Sizing

Batteries are the inverter's fuel tank. The larger the batteries, the longer the inverter can operate before recharging is necessary. An undersized battery bank results in reduced battery life and disappointing system performance.

Estimating Battery Requirements

In order to determine the proper battery bank size, it is necessary to compute the number of amp hours that will be used **between charging cycles**. When the required amp/hrs are known, size the batteries at approximately twice this amount. Doubling the expected amp/hr usage ensures that the batteries will not be overly discharged and extends battery life.

To compute total amp/hrs usage, the amp/hr requirements of each appliance that is to be used are determined and then added together. *Table 1* in the tables section provides a means of figuring the amp hours drawn by various types and sizes of loads. Use the table as follows: (1) enter on the left with the row of the appropriate appliance or wattage (2) enter from the top with the column of the length of time the appliance will be run between charge cycles, (3) the intersection of row and column provides the amp hours that will be consumed.

Follow this procedure for each item you want to use with the inverter. Add the resulting amp hour requirements. The minimum properly sized battery bank will be double this amount.

If you haven't forgotten your high school algebra you may wish to compute your battery requirements using the nameplate rating of your appliances. The critical formula is $Watts = Volts \times Amps$. Divide the wattage of your load by the battery voltage to determine the amperage the load will draw from the batteries. Multiply the amperage times the hours and you have, reasonably enough,

amp/hrs. Remember that periods of time less than an hour will be fractions (10 minutes is 1/6 of an hour).

Notes: If the AC current is known, then, the battery amperage will be:
 $AC\ current \times AC\ voltage \div \text{the battery voltage}.$

Motors are normally marked with their running current rather than their starting current. Starting current may be 3 to 6 times running current.

Hook-up Configurations

Battery banks of substantial size are generally created by connecting several batteries together. There are three ways to do this. Batteries may be connected in series, parallel or series/parallel.

Series Connection

When batteries are connected with the plus terminal of one to the minus of the

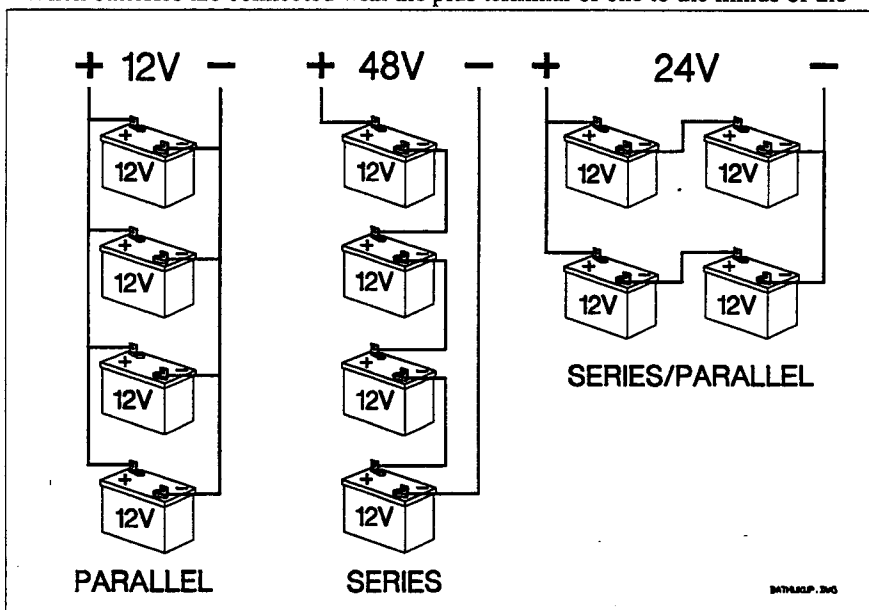

Figure 4, Connecting Multiple Batteries

next, they are in series. A group of batteries in series has the amp/hour rating of a single battery but a voltage rating equal to the sum of the individual batteries voltages.

Parallel Connection

Batteries are connected in parallel when all the positive terminals of a group of batteries are connected and, then, all the negative terminals are connected. In parallel, batteries have the voltage of a single battery and an amp/hour rating equal to the sum of the individual batteries.

Series Parallel Connection

As the name implies, both of the above techniques are used in combination. See figure 4.

Installation

Environment

Inverters are sophisticated electronic devices and should be treated accordingly. When selecting the operating environment for the inverter, don't think of it in the same terms as other equipment that works with it, e.g. batteries, diesel generators, motor generators, washing machines etc. It is a highly complex device. There are nearly 50,000 silicon junctions in its output devices and integrated circuits. The crystal oscillator runs at 4 megahertz. The drive circuitry timing is accurate to a thousandth of a second. Genetically speaking, it is a cousin to stereo equipment, television sets or computers. The use of conformal coated circuit boards, plated copper buss bars, powder coated metal components, and stainless steel fasteners improves tolerance to hostile environments. However, in a condensing environment (one in which humidity and/ or temperature change cause water to form on components) all the ingredients for electrolysis are present - water, electricity and metals. In a condensing environment the life expectancy of the inverter is indeterminate and the warranty is voided.

Caution: It is in your best interests to install the inverter in a dry, protected location away from sources of high temperature and moisture. Exposure to saltwater is particularly destructive and potentially hazardous.

Locate the inverter as close to the batteries as possible in order to keep the batteries cables short. However, do **not** locate the inverter in the same compartment as the batteries. Batteries generate hydrogen sulfide gas which is very corrosive to electronics equipment - and everything else. They also generate hydrogen and oxygen. If accumulated, this mixture could be ignited by an arc caused by the connecting of battery cables or the switching of a relay.

Do not mount the inverter in a closed container. To operate at high power for sustained periods of time, unrestricted air flow is required to cool the heat sink. Without it, the protection circuitry will activate thus reducing the power available.

The inverter may be mounted on a vertical or horizontal surface, in any orientation using the four holes on the bottom flanges. However, mounting it on a shelf with its heat sink near the edge will minimize activation of the cooling fan. UL specification 1741 (photovoltaic installations) requires that the keyhole slots not be used for mounting.

In RV, marine, and other mobile installations it is advantageous to mount the inverter so that it is isolated from vibration.

Treat the inverter as you would any fine piece of electronic equipment.

AC Wiring

Overview

The National Electrical Code (NEC) defines the standards for AC and DC installation wiring in residential, commercial and RV applications, but there are still many installation variables. Most are determined by the level of automatic switching desired, the amount of external AC power to be switched and whether or not the inverter has the built-in battery charger option with its automatic transfer capability. Other wiring variations result from the fact that the standards for Marine installations are different from those for residential use.

The fundamental difference between Marine and residential use is the technique used for grounding on the AC side. Residential systems are always "polarized" - Neutral connected to safety ground - at the AC panel, never at the inverter. Marine systems are polarized on the dock at the shore power panel - not on the boat - when AC is supplied by shore power. When shore power is disconnected, system polarity can only come from the AC source on the boat. This could be the inverter or generator. On Trace "M" Series inverters, the AC output is polarized when the unit is operating as an inverter, and non-polarized when operating as a charger.

Here is another way to look at this grounding difference between Marine and residential applications. In a residence, the AC neutral is always earth grounded at the panel. In a boat, the AC panel's ground to neutral is lost when shore power is disconnected. It must be made by the new AC source if the system is to remain polarized. RV installations are similar to boat installations in respect to shore power connection, but RV industry standards do not deal with the ground switching issue. Since all 12 and 24 volt models of Trace 2500 series inverters meet or exceed RVIA guidelines, the RV customer may select a model with or without ground switching.

AC Connections

Installation should be done by a qualified electrician. Consult local code for the proper wire sizes, connectors and conduit.

A five station external terminal block is provided to make the AC connections. The terminal block is located on the right-hand side of the inverter. A cover box for the terminal block is packed separately in the shipping box. On standard models, the terminal block is used only for hardwiring the inverter's AC output. With the standby option, the terminal block is also used to hardwire the AC input. Consult your local code for proper wire sizes, connectors, conduit, etc. For 120 VAC units, we recommend 10 gauge for the standard model and 6 gauge for units with the standby option. 10 AWG is suitable to carry the inverter's output. 6 AWG is suitable for carrying the combination of 22 amps for the charger and 30 amps for the pass thru current. Code requires that an external disconnect switch be used in the AC input wiring circuit. The AC breakers in a sub panel will meet this requirement.

Disconnect the inverter from the battery. Feed the wires thru the wire ties on the side of the inverter. See *Figure 5*. Following the wiring guide on the side of

the chassis, connect the hot(black), neutral (white) and safety (green) wires to the terminal block and tighten securely. Tighten the wire ties by pulling on their ends until the loop fits snugly about the wires. Trim the end(s) of the wire tie(s).

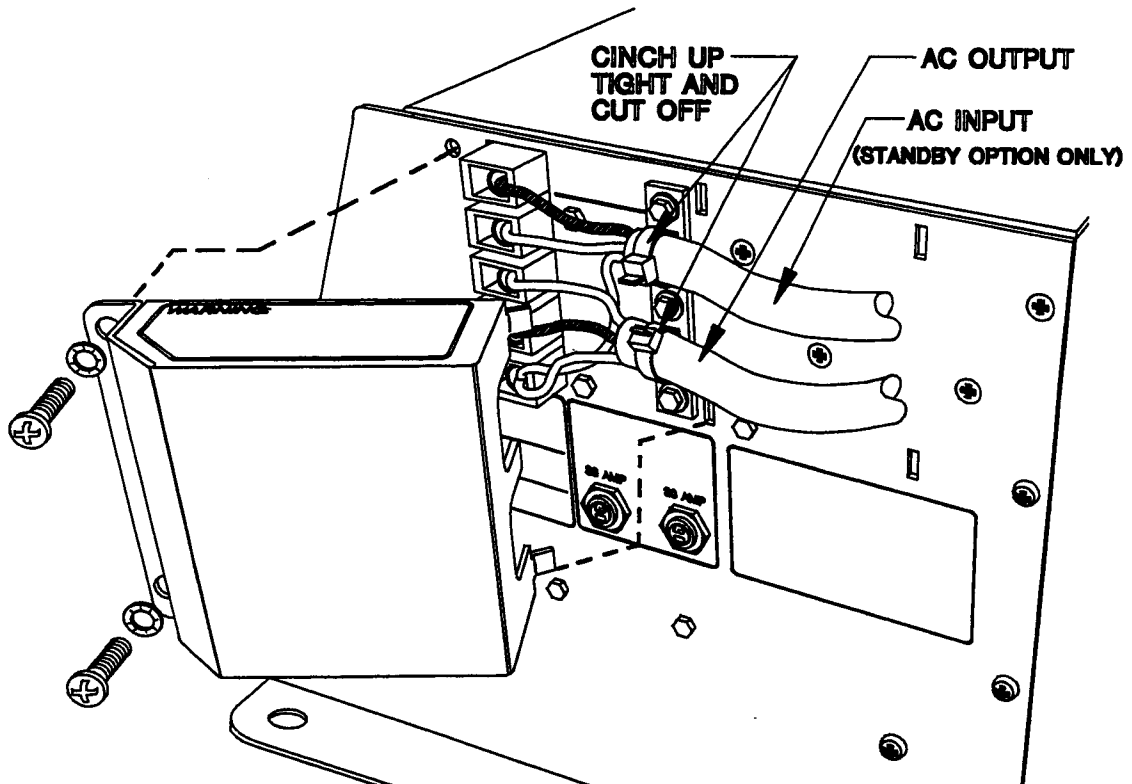

Figure 5, Hardwire Terminal

The cover box for the terminal strip has two tabs that face to the back of the inverter. Insert these tabs into the rectangular slots on the inverter's side and close the cover. Install the two 6-32 screws and lockwashers to secure the cover.

Ground Fault Interrupting Outlets (GFI's)

Trace Engineering has tested the following GFI's and found them to work satisfactorily with our inverters:

LEVITON	6599-W
PASS & SEYMOR	1591RI 4A957
ACE Hardware	ACE 33238

Important Precautions

The output side of the inverter's AC wiring should at no time be connected to public power or a generator. This condition is far worse than a short circuit. If the unit survives this condition, it will shut down until corrections are made.

On standby models the installation should ensure that the inverter's AC output is, at no time, connected to its AC input.

Review the installation diagrams included before you start making connections.

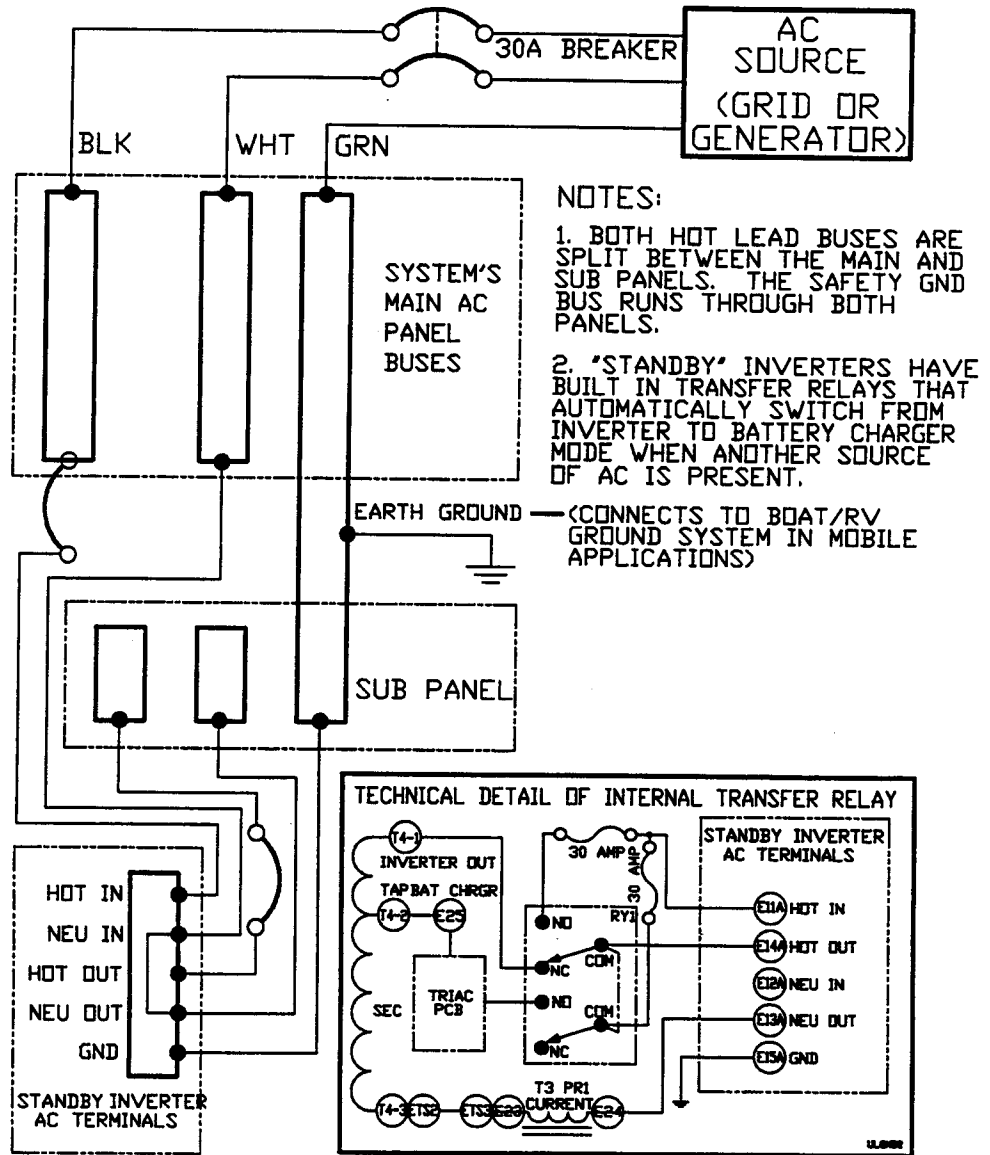

Figure 6, Typical Residential/Commercial Series Installation (Also Applies To Non-Polarized Mobile Installations)

Figure 6, Typical Residential/Commercial Installation

DC Wiring

Safety Instructions

THIS INVERTER IS NOT REVERSE POLARITY PROTECTED. If the positive terminal of the battery is connected to the negative terminal of the inverter and vice versa, the result will be instantaneous failure of nearly every power FET. To compound your misfortune, this type of failure is very obvious, and is **not covered under the warranty**. So, pay close attention and double-check when making the battery connections.

The inverter's maximum peak current requirements are high. If battery cables are too small and/or connections are loose, efficiency and maximum output power are degraded. Small cables or loose connections can also cause dangerous overheating of the wire and/or terminals.

Make the battery cables as large and as short as possible. Tape the battery cables together. This reduces the inductance of the wire resulting in a better waveform and less current in the inverter's filter capacitors.

Code your battery cables with colored tape or heat shrink tubing. Cable ends must have crimped and soldered copper ring terminals.

DC Disconnect

In order to comply with the UP 1778 safety standard (residential installations) a UL approved form of battery disconnect is required. These installation parts are not supplied by Trace Engineering. They may be obtained from your dealer, electrical supply houses or:

Industrial Controls Supply Company
22410 70th Ave West Unit 6
Mountlake Terrace, Wa. 98043
Phone (206) 771-6344
Fax (206) 775-8901

Battery Cable Connection

Observe Battery Polarity! Place the ring terminal over the bolt and directly against the inverter's copper terminal. Tighten the 5/16 nut to 10-15 ft./lbs.

Note: Connecting the battery cables to the inverter battery terminals will cause an arc - usually accompanied by a "snap". This is normal - don't let it scare you.

Never disconnect the battery cables while the inverter is delivering power or battery charger is operating. Always turn the unit off first.

OBTAIN FROM DEALER, ELECTRICAL SUPPLY HOUSE OR INDUSTRIAL CONTROLS SUPPLY COMPANY
 PHONE 1-800-736-2336, 1-206-771-6344, FAX 1-206-775-8901
 22410 70TH AVE. W. UNIT #6, MOUNTLAKE TERRACE, WA, 98043
 THESE UL REQUIRED SAFETY PARTS ARE NOT SUPPLIED BY TRACE ENGINEERING

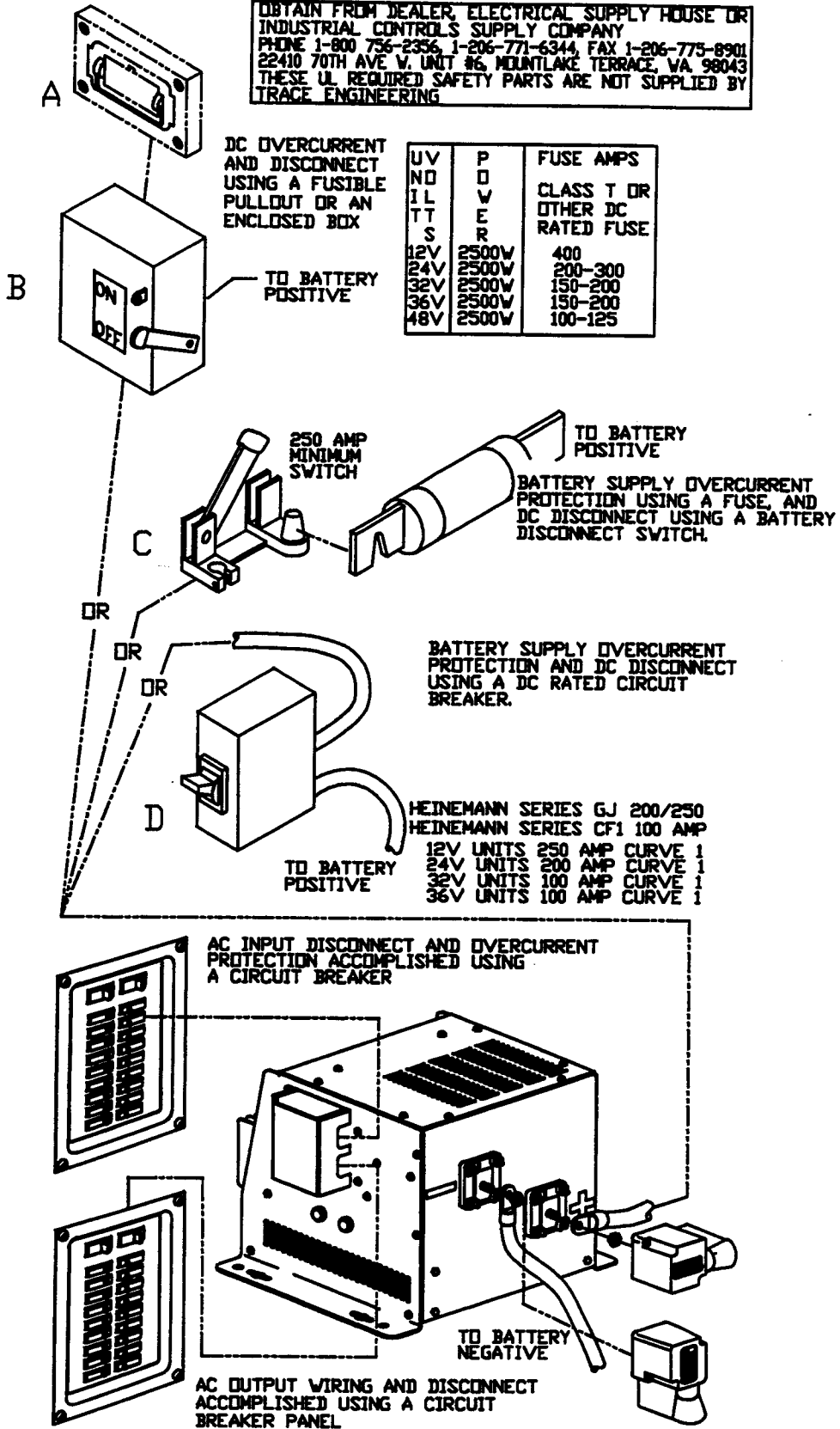

Figure 7, DC System Safety Wiring Requirements

Battery Cable Sizing

The bigger the battery cables the better. Under sized cables result in additional stress on the inverter, lower efficiency, reduced surge power and lower peak output voltage. Don't use cables that are too small and degrade the efficiency that we have worked so hard to achieve and you have paid so much to own. The following table gives recommended cable sizes for various cable run lengths and inverter voltages..

**Table of Minimum Recommended Battery Cable Size
Cable Length**

DC Volts	Under 5 ft	5 to 10 ft	10 to 20 ft
12	00	0000	0000
24	0	00	0000
32	1	0	000
36	2	0	00
48	4	1	0

WARNING !! Battery cables that are very small will melt and burn the first time the inverter is asked to produce high power.

Marine Installations

Marine installations introduce a level of complexity not found in other inverter applications due to the combination of shore power, shipboard AC and shipboard DC systems. The situation is further complicated by the often conflicting requirements of safety and corrosion/electrolysis protection. It is no wonder that a great deal of misunderstanding and diversity of opinion exists in marine wiring systems, whether or not they include power inverters. The paragraphs below attempt to clarify the situation by separately treating the controversial from the generally accepted.

Marine Mounting

The drip shield shown in *figure 8* is required to comply with marine battery charger codes. Note that keyhole slots should not be used to mount the inverter in a marine installation.

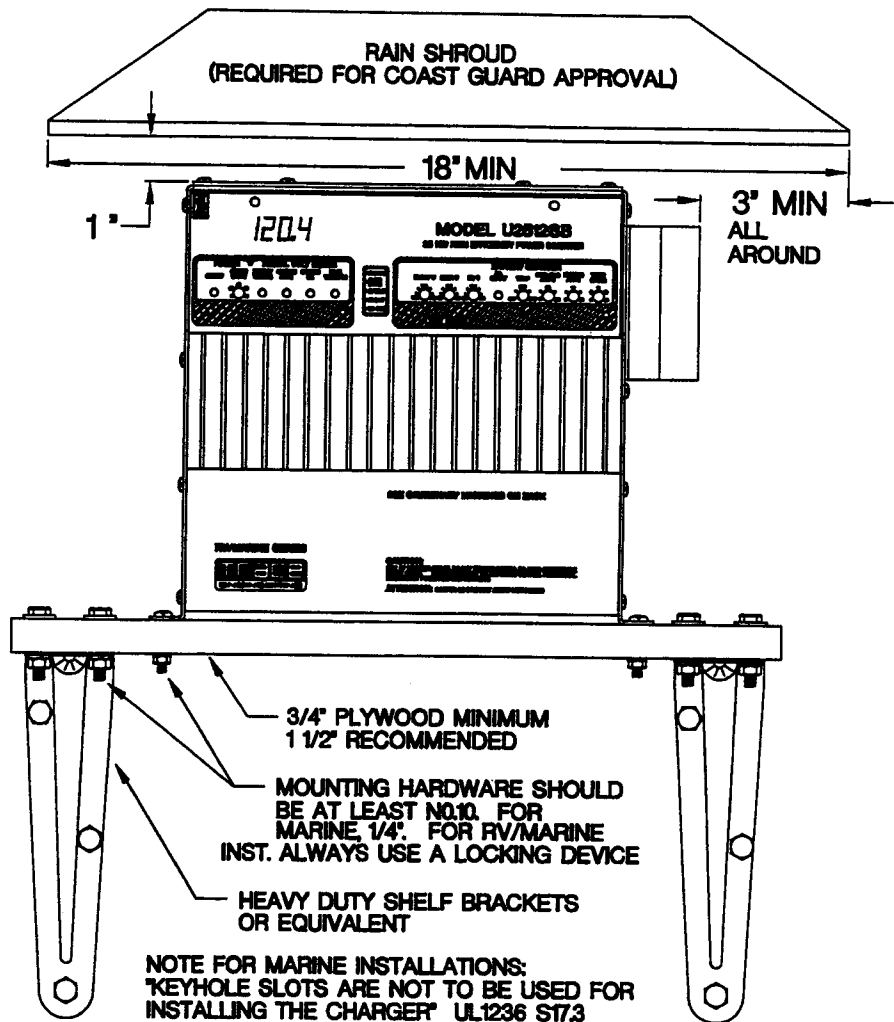
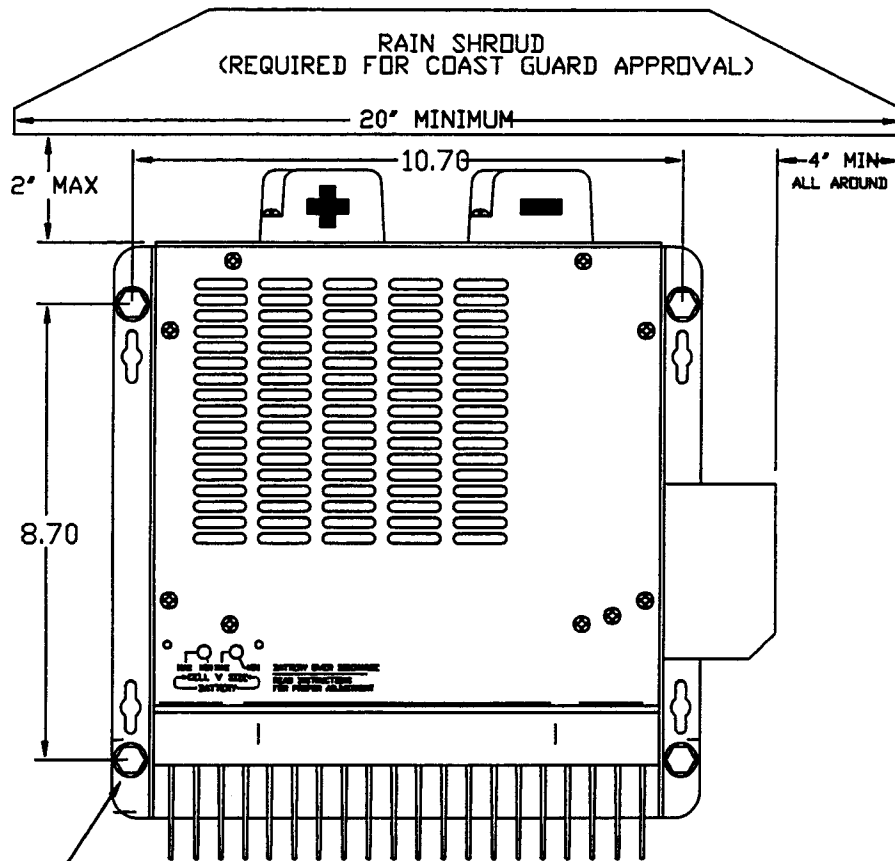

Figure 8, Drip Shroud

Shore Power Connection to Boat's Main AC Panel and Grounding System.

Wiring from the shore power input receptacle should be connected to like wire buses in the boat's main AC panel, i.e., black to black, white to white and green to green. (Note: the hot and neutral wires may first go through a selector switch to allow choice between alternate AC sources, e.g., generator and shore power.)

The green safety ground bus should always be connected to the boat's DC grounding system as a safety measure to provide protection against faults & leakage while the boat is connected to shore power. This ground connection, while providing an important safety feature, also introduces the risk of galvanic



1/4" BOLTS USING FLAT WASHERS AND LOCK WASHERS SECURELY MOUNT TO BULKHEAD. IN THE CASE OF A THIN BULKHEAD (OR SHEETROCK), MOUNT THE UNIT TO AN ADAPTER PLATE MADE FROM 3/4" MINIMUM PLYWOOD. BOLT THE ADAPTER PLATE TO THE BULKHEAD OR WALL USING 1/4" BOLTS AND WASHERS. TO REDUCE VIBRATION, 6 OR 8 BOLTS AND 1. 1/2" PLYWOOD MAY BE REQUIRED TO INSURE SUFFICIENT RIGIDITY IN A MARINE INSTALLATION.

NOTE FOR MARINE INSTALLATIONS:
 "KEYHOLE SLOTS ARE NOT TO BE USED FOR INSTALLING THE CHARGER" UL1236 S17.3

Figure 9, Marine Installation - Vertical Mounting

corrosion and/or electrolysis. Note that this risk is present in any boat with a shore power connection, whether or not it has inverters or generators on board. One of two methods are typically used to maintain the safety feature while greatly reducing (if not eliminating) the risk of corrosion/electrolysis.

1 - Galvanic Isolator Method

"Galvanic Isolators" (aka "Zinc Savers" or "Green Wire Interrupters") are relatively inexpensive devices that will provide effective electrolysis/corrosion protection on most non-metallic hull boats. They are wired between the safety ground (Green) wire of the shore power input and the safety ground bus of the boat's main AC panel. Galvanic isolators establish a low voltage block (1.5-2.0volts) that will pass a 110 volt fault, but effectively stop typical low voltage corrosion/electrolysis currents.

2 - Isolation Transformer Method

Isolation transformers are a more expensive solution to the corrosion/electrolysis problem that are typically used on metallic hull boats. They totally eliminate hardwire connections between shore power and the boat's AC wiring system, replacing them instead with induced connections through transformers. Since corrosion/electrolysis is based on DC current flow, and since transformers require AC to pass current, the problem is effectively eliminated.

Galvanic Corrosion and Electrolysis

"Galvanic Corrosion" is caused by components in the boat's electrical distribution system which form a natural battery when they are immersed in water and connected by an electrical conductor. **EXAMPLE:** Boat A with bronze propeller is tied at the dock next to Boat B with an aluminum outdrive. These dissimilar metals are immersed in salt water (a good electrolyte) and connected together electrically by the green safety ground on the shore power connection. Absent a "galvanic isolator" or "isolation transformer," the aluminum outdrive will disappear in short order!

"Electrolysis" (aka "stray current corrosion") is caused by an "impressed voltage" -- an outside source of voltage -- applied to the DC grounding system. Usually this outside source is a leakage fault in a neighboring boat's wiring.

Galvanic corrosion is typically a salt water problem. Electrolysis can be a salt or fresh water problem. One of two methods is typically used to maintain the safety feature of the green safety ground, while greatly reducing (if not eliminating) the risk of corrosion/electrolysis.

Connection of Shipboard Sources of AC Power to the Boat's Wiring System.

When AC on the boat is being supplied by shore power, the system is polarized (neutral connected to safety ground) on the dock. Consequently, neutral and safety ground should not be connected anywhere on the boat when shore power is present. When AC is being supplied by a source on the boat, i.e., inverter or generator, the system can be polarized or non-polarized. Arguments can (and have) been made for both.

In either case, the wiring connections of an inverter follow the same general guidelines as a generator, with the notable exception that inverters require connection to both the AC and the DC wiring systems for their sources of energy.

Figure 9 diagrams the installation wiring for a Trace "M" Series inverter in a polarized system.

The Case for "Polarized" (Grounded Neutral) Systems

The American Boat and Yacht Council (ABYC) recommends that a boat's AC system be "polarized" when the inverter or generator is operating. They follow the general rule that neutral and safety ground should be connected at the AC source whether that source be inverter, generator or shore power. Their underlying purpose is to establish a specification that maximizes the possibility that a circuit breaker will activate if a hot-wire-to-ground fault occurs. Their recommended system requires that the neutral/safety ground connection at the inverter

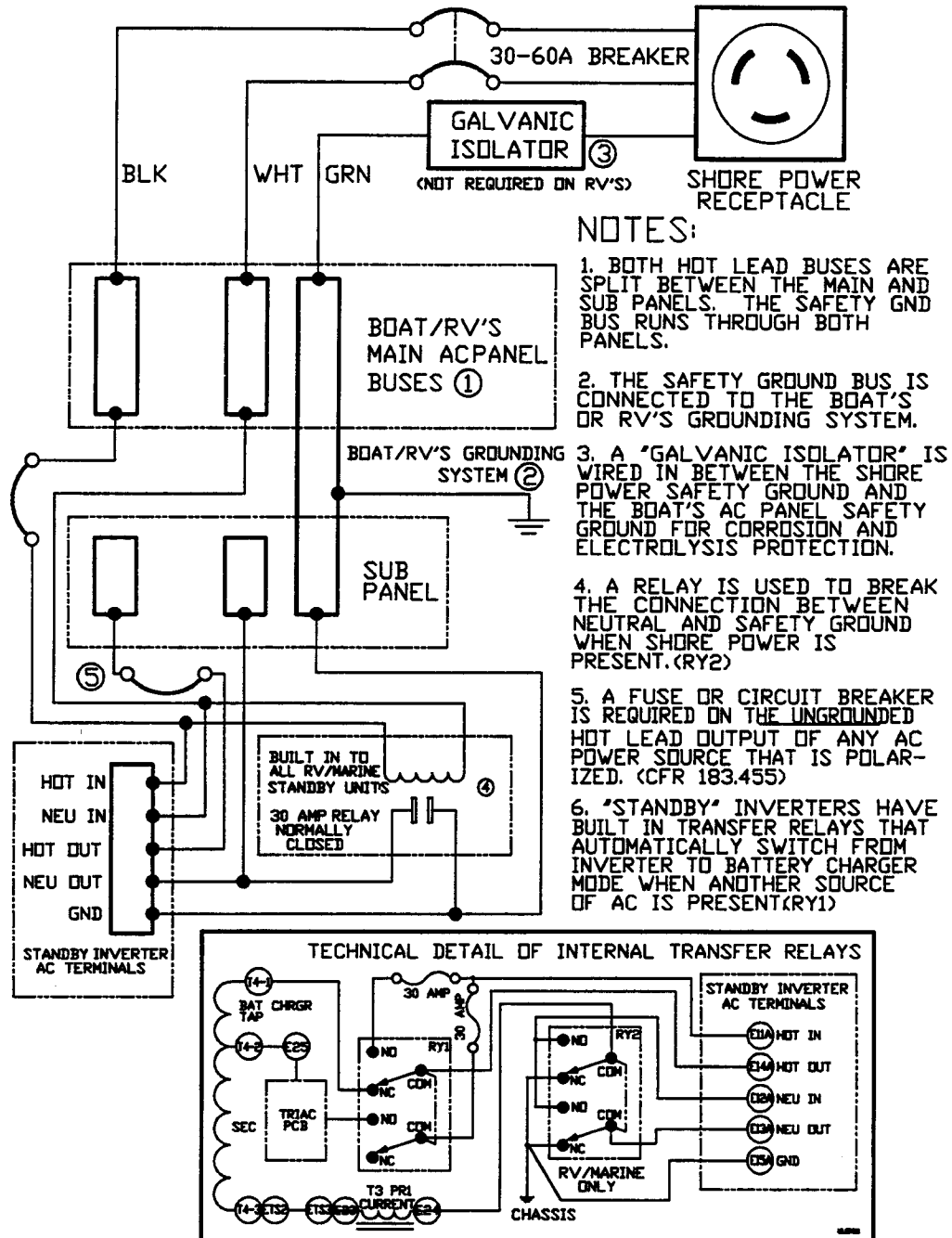

Figure 10, Polarized System for Marine Installations

or generator be enabled when the source of AC is on the boat, and disabled when shore power is connected. The Trace "M" Series inverters have a relay that does this automatically.

The Case for "Non-Polarized" (Floating Output) Systems

We are not aware of any recognized standards in the U.S. that favor a non-polarized system. However, the Canadian and European marine communities seem to favor non-polarized systems. Even in the U.S., it is a common practice for marine electricians to install non-polarized systems. Those that verbalize a reason offer these explanations:

- The safety risks of a boat's AC system are far greater when the boat is connected to shore power than when operating away from the dock.
- With a non-polarized system you can touch either hot leg and not receive a shock. You would have to touch both hot legs, or touch one hot leg when the other hot leg was shorted to ground (via a fault) to receive a shock.
- A non-polarized system essentially requires two faults to exist to present a safety hazard.
- In a polarized system, if you touch a hot wire while in contact with the water-- you will be shocked. In a non-polarized system you won't.
- Why complicate a system that is inherently quite safe and increase the risk of improper installation and lessened reliability?

Our Position

In keeping with ABYC standards for marine installations, Trace "M" series inverters were designed with automatic ground switching to polarize the inverter's AC output when operating in inverter mode. These inverters are also well-suited to RV applications. However, Trace Engineering believes that both polarized and non-polarized systems can be safe in a Marine/RV application if done properly. We recommend that if a non-polarized system is used, a fault monitoring device (indicator lights, alarms, etc.) should be employed to warn the boat operator of an unsafe condition requiring attention.

Caution: Trace "M" series inverters must not be used in residential or commercial applications where the AC neutral is grounded at the main panel. Trace residential/ commercial series (without ground switching) is the proper choice for these applications.

Installation Diagrams

A. Standby Inverter with Single AC Panel

In all installations it is important to ensure that AC power from any source (generator, public power) is never fed to the inverter's AC output. With the standby option, it is essential that the inverter's AC output is not fed to its AC input. The diagram below is simple and meets these requirements. However, there are two precautions to keep in mind:

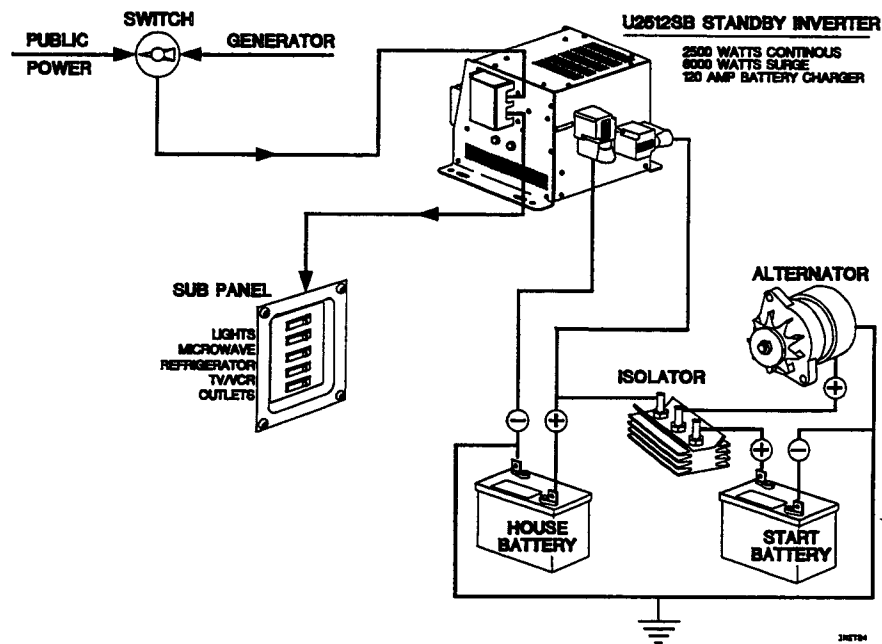

Figure 11, Marine/RV Installation with Single AC Panel

- 1) With only one AC panel encompassing **all** loads, the inverter could be connected to loads which are greater that it can run.
- 2) The maximum system current is limited by the inverter's two 30 amp AC input breakers. One breaker provides 30 amps of pass thru current, the other may supply up to 20 amps to the charger.

The above configuration is acceptable, but not recommended. Diagram "C" is preferable in that it isolates the inverter from inappropriate loads.

B. Standby Inverter with AC Sub Panel

This is the recommended configuration for installing an inverter with the built-in battery charger. It operates in the following manner. When there is power available at the main panel, the inverter's automatic transfer relay closes, connecting the main panel to the sub-panel. When there is no AC present at the main panel, the relay opens and the sub-panel is fed AC power generated by the inverter.

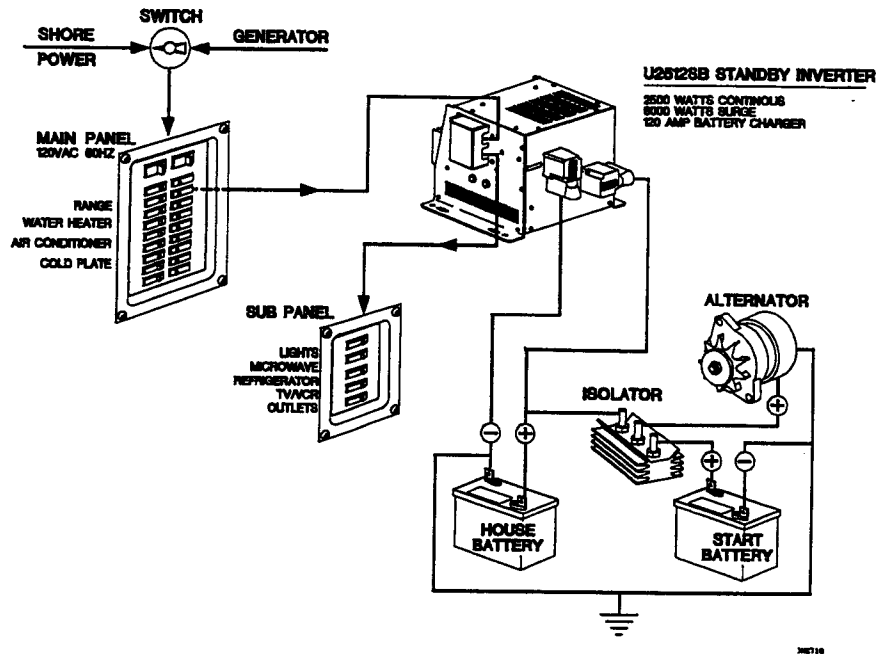

Figure 12, Marine/RV Installation - 2512M w/ AC Sub panel

This installation automatically ensures that public or generator AC power is never routed to the output of the inverter. The inverter's AC output cannot be fed to its input. Additionally, the inverter will only be connected to appropriately sized loads that are dedicated to the sub-panel.

The maximum sub panel current is limited by the inverter's two 30 amp AC input breakers. One breaker provides 30 amps of pass thru current, the other may supply up to 20 amps to the charger.

C. Standby Inverter with AC Sub Panel and Solar Array

This installation is similar to Figure 7 on the previous page--except that a solar array and wind generator are included.

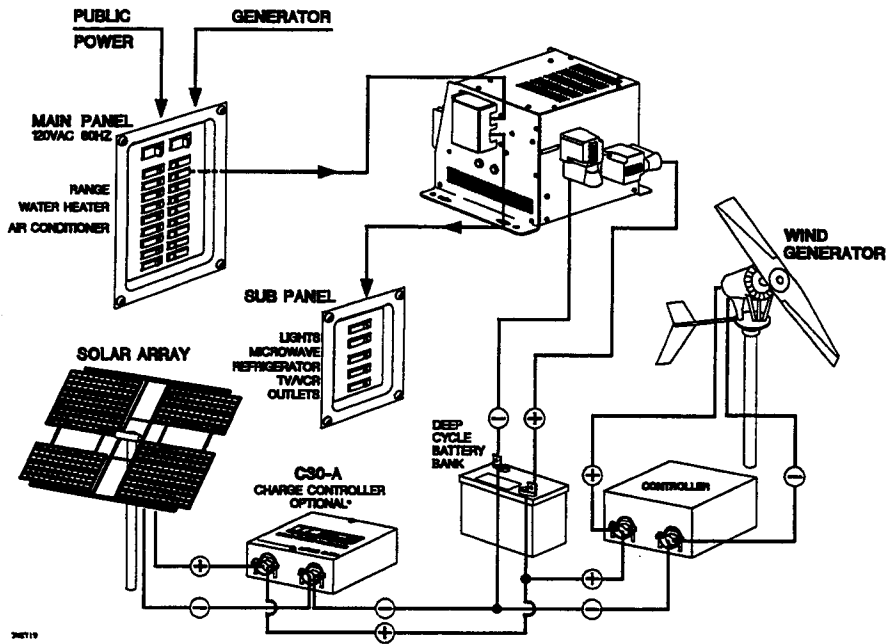

Figure 13, Renewable Energy Installation

D. Inverter with Single AC Panel and External Relay

In all installations it is important to ensure that AC power from any source (generator, public power) is never fed to the inverter's AC output. The diagram below is simple, automatic and meets this requirement. Keep in mind that with only one AC panel encompassing all loads, the inverter could be connected to loads which are greater that it can run. For this reason, it is an acceptable, but not a recommended configuration.

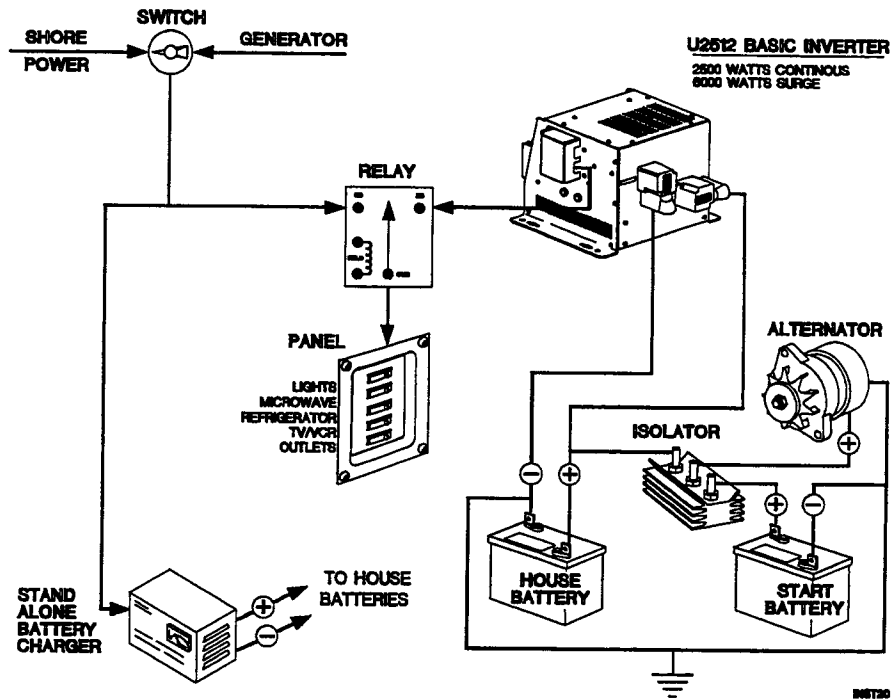

Figure 14, Inverter with Single AC Panel and External Relay

E. Inverter with an AC Sub-Panel and External Relay

This is the recommended configuration for installing an inverter without the built-in battery charger. It operates in the following manner. When there is power available at the main panel, the relay closes connecting the main panel to the sub-panel. When there is no AC present at the main panel, the relay opens and the sub-panel is fed AC power generated by the inverter.

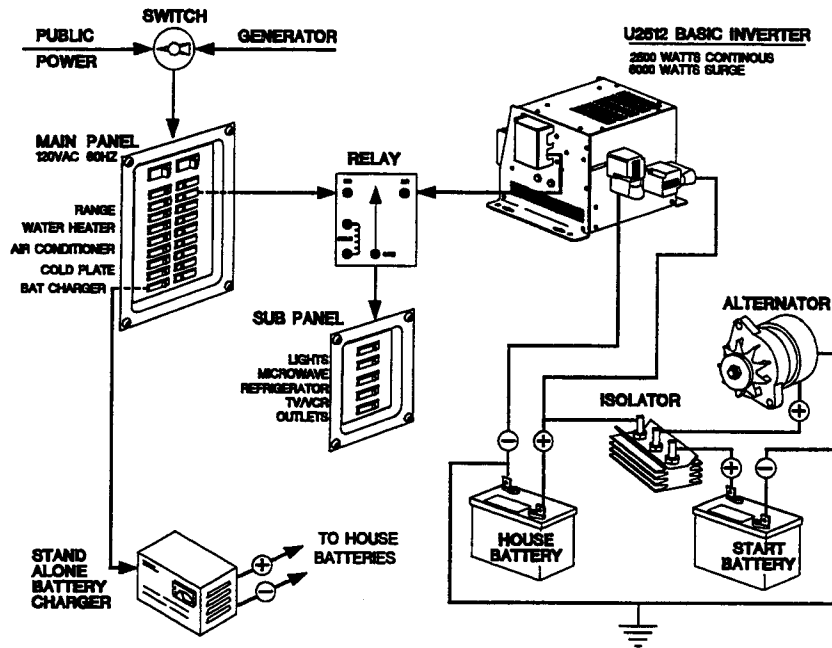

Figure 15, Inverter with Sub-Panel and External Relay

This installation automatically ensures that public or generator AC power is never routed to the output of the inverter. This setup also ensures that the inverter will only be connected to appropriately sized loads.

F. External Transfer Relay Details

Using a transfer relay allows the AC panel to be automatically connected to the output of the inverter or the generator.

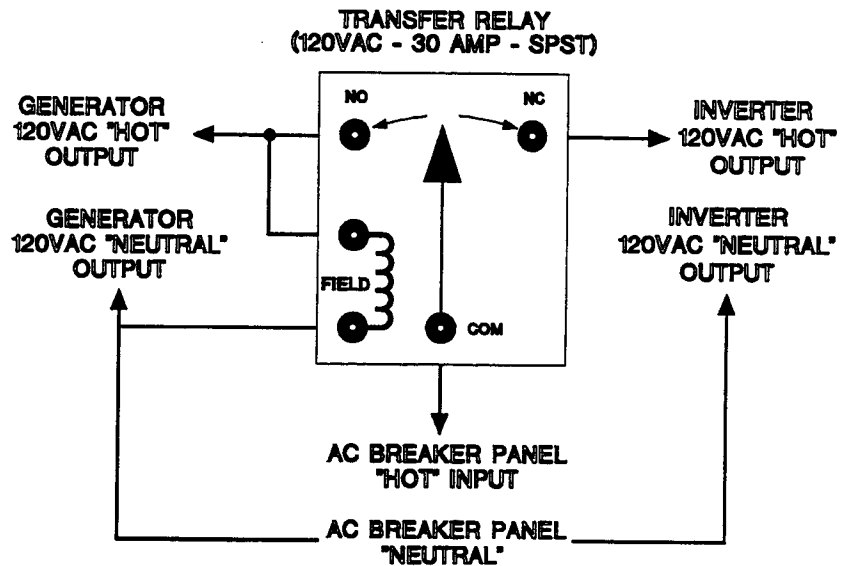

Figure 16, External Transfer Relay

The proper relay to use is described as single pole - double throw - 30 amp - 117 VAC. These relays are commonly available at electrical supply outlets for a cost of about \$14.00. Pre-wired relays enclosed in electrical panel boxes are also available thru system suppliers. These range in price from \$75 to \$250.

G. Standby Inverter with External Relay

This configuration may be desirable when the pass thru current required is greater than 30 amps.

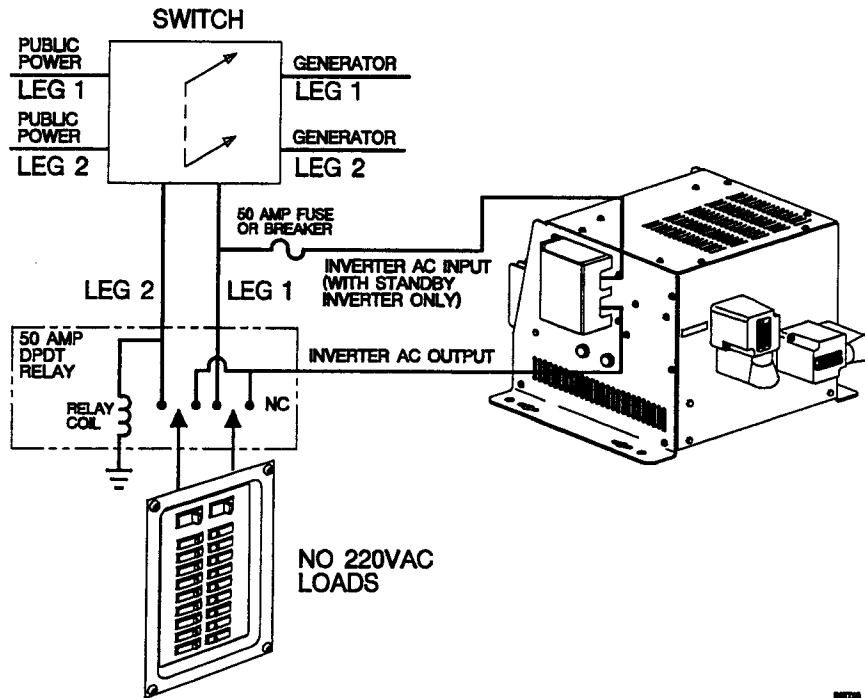

Figure 17, Generator with External Relay

When the AC panel is being run by the generator, leg 1 and leg 2 of the generator are connected independently to the two halves of the AC panel. When the inverter is operating, both sides of the AC panel are automatically connected together.

Do not use this system if there are 220 VAC loads

Trouble Shooting Guide

<u>Symptoms</u>	<u>Problem</u>	<u>Remedy</u>
No power output and no warning LED's	Battery voltage at the inverter's terminals is too high or low	Check the battery condition
	Battery overdischarge protection circuit set too high	Lower cutout voltage and/or battery bank size setting
	Load too small for Search Mode circuit to detect	Reduce search threshold setting or defeat the Search Mode
	ComPort Accessories are improperly installed	Re-install or remove options from the ComPort
No power output and warning LED's "ON"	High or Low Battery LED "ON"	Check the battery voltage at the inverter terminals
	Overload LED is "ON"	Remove loads from the inverter and restart
	High Temp LED is "ON"	Remove loads and let the inverter cool down before restarting
Power output is low and inverter turns loads on and off	Low battery	Check charge and condition of batteries
	Loose or corroded battery connections	Check and clean all connections
	Loose AC output connections	Check all AC output connections
Inverter clicks every 10 to 15 seconds interrupting power	Output of inverter wired back to the input (standby model only)	Check for proper AC input and output wiring
Charger is inoperative or intermittant	AC input voltage does not match inverter spec	Check AC input for proper voltage and frequency of your model
	Charger controls improperly set	Refer to Owner's Manual for proper setting of battery charger parameters
Low charge rate	Low <u>peak</u> AC input voltage (164 volts peak required for full charger output)	Use larger generator, speed up generator, check AC input wiring size, adjust charge rate, cable too small or too long
	AC current too small to handle load	Reduce charge amps setting and/or shed pass through loads
Low AC output voltage	Measuring with the wrong type voltmeter	Voltmeter must be a true RMS reading meter (most are not)
Low surge power	Weak batteries, battery cables too small or too long	Refer to cable and battery recommendations in owner's manual

Applications

Resistive Loads

These are the loads that the inverter finds the simplest and most efficient to drive. Voltage and current are in phase, or, in this case, in step with one another. Resistive loads usually generate heat in order to accomplish their tasks. Toasters, coffee pots and incandescent lights are typical resistive loads. Larger resistive loads--such as electric stoves and water heaters--are usually impractical to run off an inverter. Even if the inverter could accommodate the load, the size of battery bank required would be impractical.

Inductive Loads

Any device that has a coil of wire in it probably has an inductive load characteristic. Most electronics have transformers (TV's, stereos, etc.) and are therefore inductive. Typically, the most inductive loads are motors. The most difficult load for the inverter to drive will be the largest motor you manage to start. With inductive loads, the rise in voltage applied to the load is not accompanied by a simultaneous rise in current. The current is delayed. The length of the delay is a measure of inductance. The current makes up for its slow start by continuing to flow after the inverter stops delivering a voltage signal. How the inverter handles current that is delivered to it while it is essentially "turned off", affects its efficiency and "friendliness" with inductive loads. The best place for this out of phase current is in the load, and Trace's "impulse phase correction" circuitry routes it there.

Inductive loads, by their nature, require more current to operate than a resistive load of the same wattage rating, regardless of whether power is being supplied by an inverter, a generator or grid.

Induction motors (motors without brushes) require 2 to 6 times their running current on start-up. The most demanding are those that start under load, eg. compressors and pumps. The largest motor of this type that the inverter will run varies from 1/3 to 3/4 hp. Of the capacitor start motors, typical in drill presses, band saws, etc., the largest you may expect to run is 1 to 1.5 hp. Universal motors are generally easier to start. The inverter may start up to 2.5 hp universal motors. Since motor characteristics vary, only testing will determine if a specific load can be started and how long it can be run.

If a motor fails to start within a few seconds, or it begins to lose power after running for a time, it should be turned off. When the inverter attempts to start a load that is greater than it can handle, it will turn itself off after about 20 seconds.

Problem Loads

TRACE ENGINEERING inverters can drive nearly every type of load. However, there are special situations in which inverters may behave differently than public power.

- **Very small loads:** - If the power consumed by a device is less than the threshold of the search mode circuitry, it will not run. See the section called "Search Mode Control" for ways to solve this problem.
- **Fluorescent lights & power supplies** - Some devices when scanned by the load sensor cannot be detected. Small fluorescent lights are the most common example. (Try altering the plug polarity-turn the plug over). Some computers and sophisticated electronics have power supplies that do not present a load until line voltage is available. When this occurs, each unit waits for the other to begin. To drive these loads either a small companion load must be used to bring the inverter out of its search mode, or the inverter may be programmed to remain at full output voltage. See the section "Search Mode Control."
- **Microwave ovens** - Microwave ovens are sensitive to peak output voltage. The higher the voltage, the faster they cook. Inverter peak output voltage is dependent on battery voltage and load size. The high power demanded by a full sized microwave will drop the peak voltage several volts due to internal losses. Therefore, the time needed to cook food will be increased if battery voltage is low.
- **Clocks** - The inverter's crystal controlled oscillator keeps the frequency accurate to within a few seconds a day. However, external loads in the system may alter the inverter's output waveform causing clocks to run at different speeds. This may result in periods during which clocks keep time and then mysteriously do not. Most clocks do not draw enough power to trigger the load sensing circuit. In order to operate without other loads present, the load sensing will have to be defeated. (See section on Search Mode Control.)
- **Searching** - If the amount of power a load draws decreases after it turns on, and if this "on" load is less than the load sensing threshold, it will be turned alternately on and off by the inverter.
- **Ceiling Fans** - Most large diameter, slow turning fans run correctly, but generate more noise than they would connected to public power. The high speed type fans operate normally.
- **Dimmer Switches** - Most dimmer switches lose their ability to dim the lights and operate either fully on or off.
- **Rechargeable Devices** - Sears "First Alert" flashlights fail when charged by the inverter. "Skil" rechargeable products are questionable. Makita products work well. When first using a rechargeable device, monitor its temperature for 10 minutes to ensure that it does not become abnormally hot. That will be your indicator that it should not be used with the inverter.
- **Laser Printers** - While many laser products are presently operating from TRACE ENGINEERING inverters, and we have personally run a Texas Instruments Microlaser and HP IIP, we have had reports of an

HP III and a MacIntosh Laser Writer failing under inverter power. We, therefore, do not recommend the use of laser printers.

- **Electronics** - AM radios will pick up noise, especially on the lower half of their band. Inexpensive tape recorders are likely to pick up a buzz. Large loads should not be started while a computer is operating off the inverter. If a load is large enough to require "soft starting" it will "crash" the computer.
- **Low Battery Dropout** - The inverter will turn off to protect itself if your battery bank cannot deliver the necessary amperage to drive a particular load without falling below the low voltage protection point for three seconds. With the inverter off, the battery voltage will rise and then it will resume operation. Since this cycling happens quickly it can be mistaken for a problem with the inverter.

Technical Information

Design Goals

To achieve high efficiency levels, the inverter design must attack power transfer losses from multiple sources.

Efficiency

The primary types of power transfer losses must be minimized in order to run efficiently.

- **Transformer Loss-** Transformer design and construction have a considerable effect on inverter efficiency. The characteristics that make a transformer efficient at high power make it inefficient at low power. Trace transformer designs favor high power efficiency, and use sophisticated search mode circuitry to maintain efficiency at low power. Special winding techniques - previously used only in very high power equipment - are employed to further enhance high power performance.
- **Transistor Loss -** The FET's (field effect transistors) used in the output stage act like resistors. The more FET's that are put in parallel, the lower their effective resistance. The lower the resistance, the lower the losses. Trace 2500 series inverters use 44 power FET's in their output stage - about double the number used in competing products. The signal that is used to turn them on and off is important to efficiency as well as reliability. The FET's should be driven on and off very quickly with the proper voltage to optimize their characteristics. A regulated switching power supply is dedicated to the output stage for this purpose.
- **Connector Loss-** All connections are tin plated copper to copper with a one square inch surface area. All primary currents are carried in bus bars to minimize losses and corrosion problems.
- **Reactive Loads -** These loads present special requirements to an inverter. The current flow is out of phase with its voltage waveform. The trailing current waveform must be properly handled or the performance of the inverter will be seriously degraded. Trace's "**impulse phase correction**" circuitry returns most of this current back to the load where it does useful work.

High Power

The ingredients for high power are a subset of those for high efficiency. High power is high efficiency at high current. Attaining maximum performance requires protection circuitry that allows full use of the FET's safe operating area. To do this, the control circuitry monitors temperature, current and time. The

transformer's low DC resistance, the low "on" resistance of the FET's, and the smart protection circuitry combine to generate substantial power from the Series 2500's small package.

In order to run loads that require more start power than run power, the inverter must be able to deliver power well beyond its continuous rating for a short period of time. This is the so-called "surge power". Its value is often determined by a company's marketing department. This is partly because there are no standards for surge power, and partly because it cannot be represented by a simple or single number. Trace 2500 series inverters can start any load that is on the edge of their time versus power envelope. Which is to say, it will start anything that it can run for at least a few minutes.

Reliability

Achieving reliability requires synthesizing a carefully controlled drive circuit design, extensive protection circuitry and sound construction techniques. A description of the drive circuit design is beyond the scope of this manual, but has been touched upon in the above discussion of efficiency.

Trace protection circuitry monitors the following conditions: low battery, high battery, short circuit, over current, reverse output voltage and temperature. Low battery voltage is not harmful to the inverter but could damage the batteries. High battery voltage can result in peak output voltages high enough to damage electronic equipment if the inverter did not automatically shut down. Battery voltage in excess of 1.5 x nominal can damage the inverter as well. Over current protection is triggered when load demands exceed the safe operating area of the transistors. Reverse output voltage protection guards the unit from accidental connection of the inverter output to public power.

Temperature protection is provided by solid state temperature sensors located on the heat sink and transformer. The power that a semiconductor can deliver is in part dependent upon its temperature. Therefore, the protection scheme adjusts the protection parameters linearly according to temperature. This utilizes the full capability of the FET's. If either sensor exceeds a threshold (heatsink-80 deg.C, transformer-170 deg.C) the inverter shuts down. Forced air cooling improves the inverter's life expectancy, especially if it sees substantial use at high powers.

Trace construction methods employ Motorola's "tight packaging technique". This refers not to the size of the unit, but rather the concept of keeping all drive signal paths as short as possible. Consistent performance and superior reliability are assured by minimizing the use of wires and locating nearly all circuitry contained on one double -sided, thru-hole plated printed circuit board.

MODEL U2512 SPECIFICATIONS

Rated Power @ 20 deg.C	2500 watts continuous
Surge Power	8000 watts incandescent lights
Motor Starting Current	45 RMS amps with 12 VDC battery
Efficiency	85-96% from 50 watts to rated output
Input current028 amps / .33 watts in search mode .600 amps idling with search mode defeated 265 amps at rated power 950 amps short circuit
Load sensing (watts)	Adjustable from 5 to 80 watts, or defeated
Input voltage (VDC)	10.8 to 15.6 to maintain regulated output voltage 8.8 to 10.8 non-regulated output voltage Below 8.8 or above 15.6 subject to inverter shutdown with auto reset
Output voltage regulation	120 VAC +/- 2 % RMS 220 VAC +/- 2% RMS - W model 240 VAC +/- 2% RMS - U model 100 VAC +/- 2% RMS - K model
Frequency regulation	Crystal controlled +/- .04%
Power factor of load	All conditions allowed (-1 to 1)
Wave form	Modified sine wave, dynamic impulse phase correction for inductive loads
Reverse polarity	1800 amp maximum
Protection circuitry (with auto reset)	
High battery	above 15.6V with (auto reset) return below 14.8V
Low battery	below 9V for 3 sec.
Overcurrent	instantaneous limiting with linear temperature compensation
Protection circuitry (with manual reset)	
Extended over current	greater than 20 seconds
AC Backfeed	input connected to output
Battery protector activation	Load compensated battery voltage (factory preset at 1.6 volts per cell and minimum battery bank size)
Environmental Characteristics	
Operating ambient temperature	0 C to +60 C
Non-operating ambient temperature	-55 C to +75 C
Altitude operating	to 15,000 ft.

Altitude non-operating to 50,000 ft
 Dimensions Height 9.75", width 11.5", depth 13.5"
 Weight 42 lbs.

Standby Feature (Battery Charger)

Charge Program 3 stage - Bulk (constant current), Absorption
 (constant voltage), Float (constant voltage)
 Bulk Charge Rate Adjustable from 0 To 120 Amps
 Bulk Charge Voltage Adjustable from 14.1 To 14.7 VDC
 Float Voltage Adjustable from 12.9 to 13.5 VDC
 Return Amps Adjustable from 0 to 20
 Equalize Voltage Adjustable from 15.5 to 16.1
 Charge/Equalization Safety Timer Adjustable from 2 To 20 Hours
 Temperature Compenstation Adjustable from 20 F To 100 F (-3.9mv/deg.c)
 Automatic Transfer Relay 1 Hp /30 Amps
 AC Input Circuit Breakers 30 amps each for battery charger and AC pass
 through

Digital Voltmeter

Frequency 40 to 70 Hz +/- 3 digits
 Battery Voltage 9 to 16 volts - +/- 3 digits
 Peak Voltage 100 to 199 volts - +/- 2%
 200 to 400 volts - +/- 2%, W and U models
 Charge Rate 0 to 20 amps - +/- 10%
 20 to 80 amps - +/- 5%
 80 to 120 amps - +/- 10%

All specifications based on resistive loads and 20 degrees centigrade ambient temperature. Specifications are subject to change without notice..

Options

The 2500 Series of inverters is designed to accommodate several options which may be installed by the user. The standby option can only be retrofitted by the factory.

Standby - Adds a multistage battery charger and automatic transfer switching. (Standard on Marine/RV models, optional on other models).

Digital Meter (DVM) - Adds a four-function digital meter to the standby models to monitor battery voltage, charge current, AC source frequency and AC source peak voltage. (Standard on Marine /RV models, Optional on other models.)

Remote Control (RC2000/12) - Provides a remote panel with an On/Off switch and digital voltmeter that reads the same functions as the DVM option. Status indicator lights show On/Off, search mode, error condition and AC present.

Remote Control (RC/2) - Provides an on/off switch and LED that indicates on, off, search mode and overload conditions.

Battery Cables (BC5) & (BC10) - 4/0 flexible 4000 strand cables. Color coded with crimped and soldered copper terminals. Two 5 foot or two 10 foot lengths.

Performance Graphs

Load Capacity vs. Time

Loads presented to the inverter are seldom constant. Typically, large loads are operated for only short periods of time. In order to provide the maximum utility, TRACE inverters are allowed to operate at power levels that exceed their continuous power ratings. This graph shows how loads that are larger than the inverter can sustain continuously can be operated for useful periods of time.

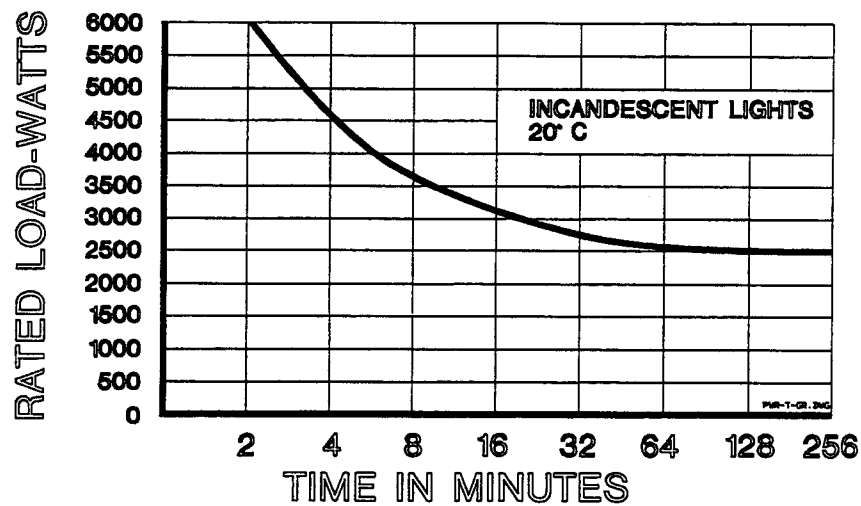

Graph 1, Load Capacity vs Time

The length of time that the inverter can operate at high power is limited by temperature. When large loads are run, the inverter's temperature increases. At the point where more heat is created in the inverter than can be dissipated, its ability to operate becomes time limited. The accompanying graph represents the typical relationship between size of load and the time it can be operated by a 2500 series inverter.

This graph assumes an ambient operating temperature of 20⁰ C and resistive loads. Reactive loads (motors, florescent lights) and/or elevated ambient temperatures will reduce the time that the inverter can operate at a particular load level.

Power vs. Efficiency

There are two primary types of losses that combine to create the efficiency curve. The first is the energy that is required to operate the inverter at full output voltage while delivering no current. This is the idle power. At low power levels it is the largest contributor to efficiency losses.

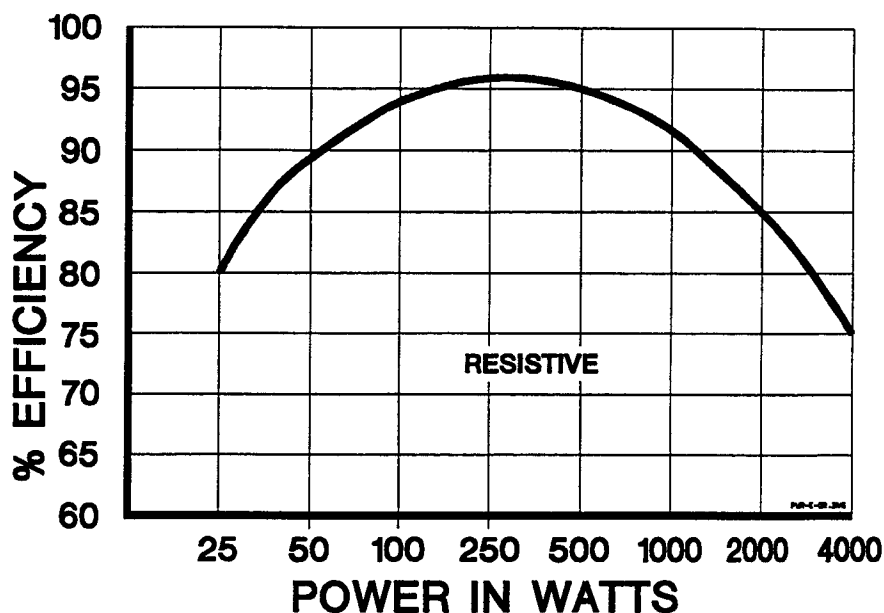

Graph 2, Power vs Efficiency

The second and largest source of loss is a result of the resistance in the transformer and power devices. The power lost here is proportional to the square of the output power. For Example, losses at 2000 watts will be four times higher than losses at 1000 watts.

This graph above represents a typical inverter's efficiency while operating resistive loads. Inductive loads such as motors are run less efficiently due to the impact of power factor losses.

Maximum Regulated Power vs Battery Voltage

The inverter regulates RMS voltage by changing the width of its output waveform. The graph below defines the points at which the combination of power and battery voltage results in squarewave output. The area above the line represents regulated output. The area below the line shows unregulated operating conditions.

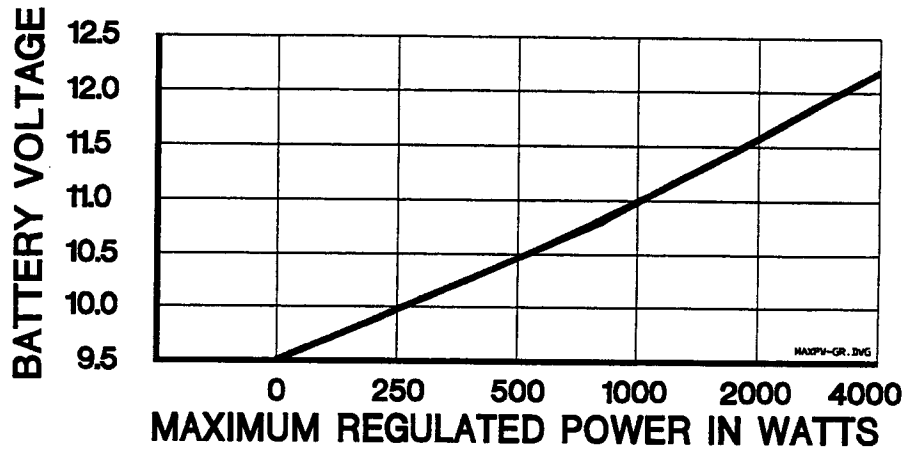

Graph 3, Battery Voltage vs Maximum Regulated Power

As the battery voltage is reduced, the maximum regulated power the inverter can produce decreases. Note that battery voltage is specified as "cell voltage." To get system voltage, multiply by six for a twelve volt system, twelve for a twenty-four volt system, etc.

Maximum Load vs Temperature

The current protection circuit is temperature compensated, ie, the maximum sized load that the inverter can run changes with temperature. As the temperature of the power devices (FET's) increases, the maximum allowable current is reduced. When the available current is reduced, the maximum size load the inverter can run is reduced.

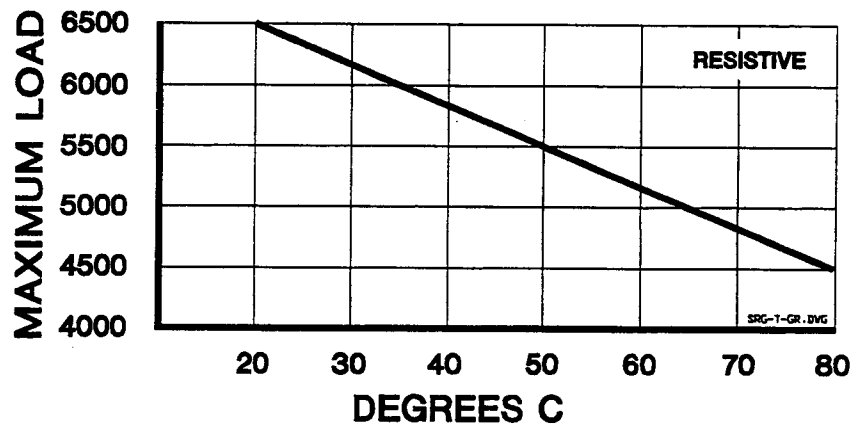

Graph 4, Maximum Load vs Temperature

The graph above shows the effect FET temperature has on maximum possible loads. While the graph shows loads up to 6000 watts, the inverter will run out of regulation well below this level. Included later in the manual is a graph depicting maximum regulated power vs battery voltage.

Charge Rate vs Peak Input Voltage

The performance of the battery charger is dependent upon the peak voltage available. This graph demonstrates the effect that peak AC voltage has upon the inverter's maximum charge rate capabilities at varying levels of battery voltage. Note that battery voltage is shown in volts per cell. Multiply by six for system voltage in a twelve volt system, twelve for a twenty-four volt system, etc.

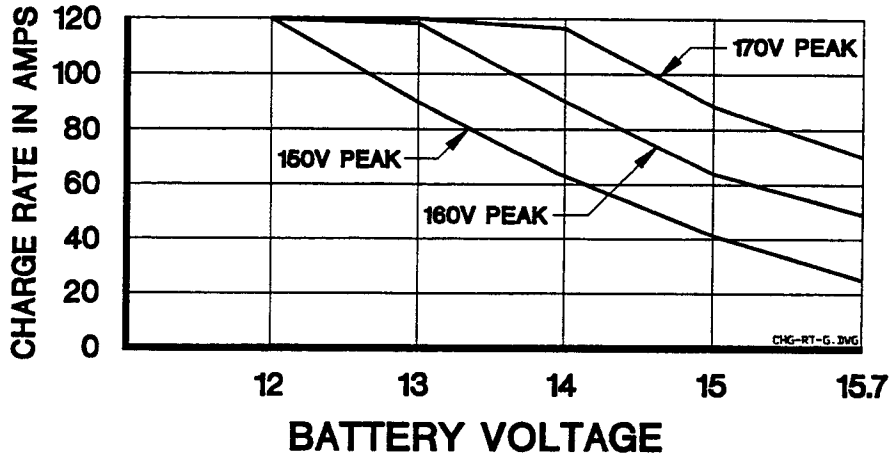

Graph 5, Charge Rate vs Peak AC Voltage

In order to meet its ratings, 164 peak volts are required. A battery charger uses only the top portion of the input sinewave. Therefore, small variations in peak voltage result in large variations in the amount of the waveform that the charger has to work with. U.S public power of 117V has a peak voltage of 164V. For voltages of 100, 220 and 240 the peak voltages are 141, 310 and 338 respectively.

TABLES

Table 1 - Typical Battery Draw of Common Appliances

Appliance	Watts	Battery Draw in Amp Hours for Run Time of:						
		5 min	15 min	30 min	1 Hr	2 Hr	4Hr	8Hr
B&W 12" TV	40	<1	1	2	4	7	15	30
Stereo or VCR	50	<1	1	2	5	9	19	37
Light Bulb	60	<1	2	3	6	11	22	44
TV-19" Color	150	1	3	7	14	28	56	111
*Refrigerator 3 cu ft	180	<1	1	3	6	11	22	44
Computer	200	2	5	9	19	37	74	148
Blender	400	3	9	19	37			
*Refrigerator 12 cu ft	480	1	4	7	15	30	59	119
3/8" Drill	500	4	12	23	46			
Microwave Compact	800	6	19	37	74			
Hair Dryer or iron	1000	8	23	46	93			
Vacuum or Coffee Maker	1200	9	28	56	111			
Microwave Full Size	1500	12	35	69	139			
12 Volt System								

Notes: If the current draw at 120 VAC is known, then the battery amperage at 12VDC will be 10 times the AC amperage divided by the efficiency (90% in this table).

Motors are normally marked with their running rather than their starting current. Starting current can be five times running current.

* Refrigerators and ice makers typically run about 1/3 of the time. Therefore, their average battery current draw is 1/3 what their amp rating would indicate.

Table 2. U.S. (AWG) to Metric Wire Size Conversion

AGW	Diameter/mm	Area/mm²
14	1.628	2.082
12	2.052	3.308
10	2.588	5.261
8	3.264	8.367
6	4.115	13.299
4	5.189	21.147
2	6.543	33.624
1	7.348	42.406
0	8.525	53.482
00	9.266	67.433
000	10.404	85.014
0000	11.684	107.219

Limited Warranty

Trace Engineering Company warrants its power products against defects in material and workmanship for a period of two (2) years from date of purchase and extends this warranty to all purchasers or owners of the product during the warranty period. Trace Engineering does not warrant its products against any and all defects: (1) Arising out of material or workmanship not provided or furnished by Trace Engineering, or (2) resulting from abnormal use of the product or use in violation of the instructions, or (3) in products repaired or serviced by other than Trace Engineering repair facilities, or (4) in components, parts or products expressly warranted by another manufacturer. Trace Engineering agrees to supply all parts and labor or repair or replace defects covered by this warranty with parts or products of original or improved design, at its option, if the defective product is returned to any Trace Engineering authorized warranty repair facility or to the Trace Engineering factory in the original packaging, with all transportation costs and full insurance paid by the purchaser or owner.

ALL REMEDIES AND THE MEASURE OF DAMAGES ARE LIMITED TO THE ABOVE. TRACE ENGINEERING SHALL IN NO EVENT BE LIABLE FOR CONSEQUENTIAL, INCIDENTAL, CONTINGENT OR SPECIAL DAMAGES, EVEN IF TRACE ENGINEERING HAS BEEN ADVISED OF THE POSSIBILITY OF SUCH DAMAGES. ANY AND ALL OTHER WARRANTIES EXPRESS OR IMPLIED ARISING BY LAW, COURSE OF DEALING, COURSE OF PERFORMANCE, USAGE OF TRADE, OR OTHERWISE, INCLUDING BUT NOT LIMITED TO IMPLIED WARRANTIES OF MERCHANTABILITY AND FITNESS FOR A PARTICULAR PURPOSE, ARE LIMITED IN DURATION TO A PERIOD OF (2) YEARS FROM THE DATE OF PURCHASE BY THE ORIGINAL RETAIL PURCHASER.

SOME STATES DO NOT ALLOW LIMITATIONS ON HOW LONG AN IMPLIED WARRANTY LASTS, OR THE EXCLUSION OF INCIDENTAL OR CONSEQUENTIAL DAMAGE. SO THE ABOVE LIMITATIONS MAY NOT APPLY TO YOU. THIS WARRANTY GIVES YOU SPECIFIC LEGAL RIGHTS. YOU MAY ALSO HAVE OTHER RIGHTS WHICH VARY FROM STATE TO STATE.

Warranty Procedure

TO VALIDATE your warranty, the warranty card must be filled out and mailed to Trace Engineering within ten (10) days from the date of purchase. It is also advised that you KEEP YOUR BILL OF SALE as proof of purchase, should any difficulties arise concerning the registration of the warranty card.

WARRANTY REGISTRATION is tracked by model and serial numbers only, not by owner's name. Therefore, any correspondence or inquiries made to Trace Engineering must include the model and serial number of the product in question. Be sure to fill in the model and serial number in the space provided below and keep this portion of the warranty card in a safe place for future reference.

WARRANTY SERVICE must be performed ONLY AT AN AUTHORIZED TRACE SERVICE CENTER, OR AT THE TRACE ENGINEERING FACTORY. It is recommended that advance notice be given to the repair facility to avoid the possibility of needless shipment. UNAUTHORIZED SERVICE PERFORMED ON ANY TRACE PRODUCT WILL VOID THE EXISTING FACTORY WARRANTY ON THAT PRODUCT.

FACTORY SERVICE: If you wish your Trace Engineering product to be serviced at the factory, it must be shipped FULLY INSURED IN THE ORIGINAL PACKAGING OR EQUIVALENT; this warranty will not cover repairs on products damaged through improper packaging. If possible, avoid sending products thru the mail. Be sure to include in the package:

1. Complete return shipping address (P.O. Box numbers are not acceptable) and telephone number where you can be reached during working hours.
2. A detailed description of any problems experienced, including the make and model numbers of any other equipment in the system, types and sizes of loads, operation environment, time of unit operation and temperature.
3. A copy of your proof of purchase (purchase receipt).

Repaired products will be returned freight C.O.D. unless sufficient return shipment funds are included with the unit.

Products sent to the factory from outside the U.S. MUST include return freight funds, and sender is fully responsible for all customs documents, duties, tariffs and deposits.

Record the model and serial number below and retain for your files:



Model _____
Serial Number _____
Date of purchase _____

DETACH THIS PAGE and MAIL or FAX to TRACE ENGINEERING

Warranty Information

Model including options _____
Serial Number _____
Purchased From _____
Location _____ Date _____
Owner's Name _____
Address _____
City _____ State _____ Zip _____
Telephone - home _____ Work _____

Where will the product be used?

- | | |
|--|---|
| <input type="checkbox"/> Primary home | <input type="checkbox"/> RV, motorhome, trailer |
| <input type="checkbox"/> Cabin / Vacation Home | <input type="checkbox"/> General office |
| <input type="checkbox"/> Pleasure boat | <input type="checkbox"/> Computer, telephone system |
| <input type="checkbox"/> Commercial boat | <input type="checkbox"/> Mobile equipment |
| <input type="checkbox"/> Standby Power | <input type="checkbox"/> Other _____ |

Type of product use (check all that apply).

- Power backup
 Alternative energy (solar, wind, water)
 Primary source of AC power
 Other _____

Where did you learn of Trace products?

Dealer _____ Catalog _____
Article in _____ Other _____
Advertisement in _____

Comments about the product you purchased: _____



5916 - 195th Street N.E., Arlington, WA 98223 Phone: (360) 435-8826 Fax: (360) 435-2229

visit our website at: www.traceengineering.com